

## NATIONAL HOMOLOGATION FORM KARTING ENGINE

<i>Manufacturer</i>	OTK KART GROUP S.R.L.
<i>Make</i>	<b>VORTEX</b>
<i>Model</i>	<b>ROK GP</b>
<i>Validity of the homologation</i>	6 years
<i>Number of pages</i>	63

*This Homologation Form reproduces descriptions, illustrations and dimensions of the engine at the time that Karting Australia conducted the homologation.*

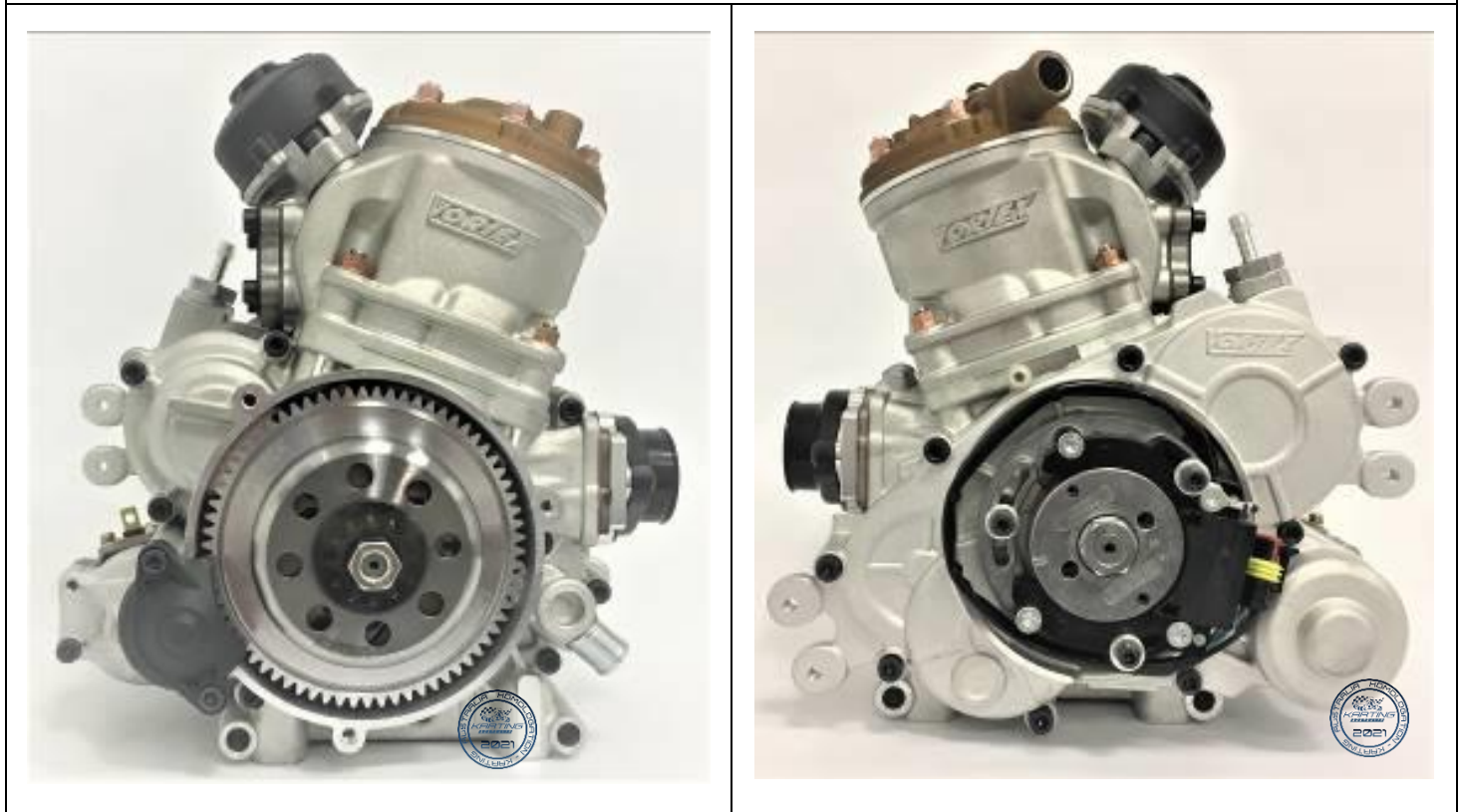

**PHOTO OF DRIVE SIDE OF ENGINE**

**PHOTO OF OPPOSITE SIDE OF ENGINE**

### Signature and Stamp of Karting Australia

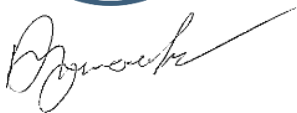
**Ashley Woolner**  
National Technical Commissioner  
14 December 2021

**PHOTO OF DRIVE SIDE OF THE COMPLETE ENGINE**

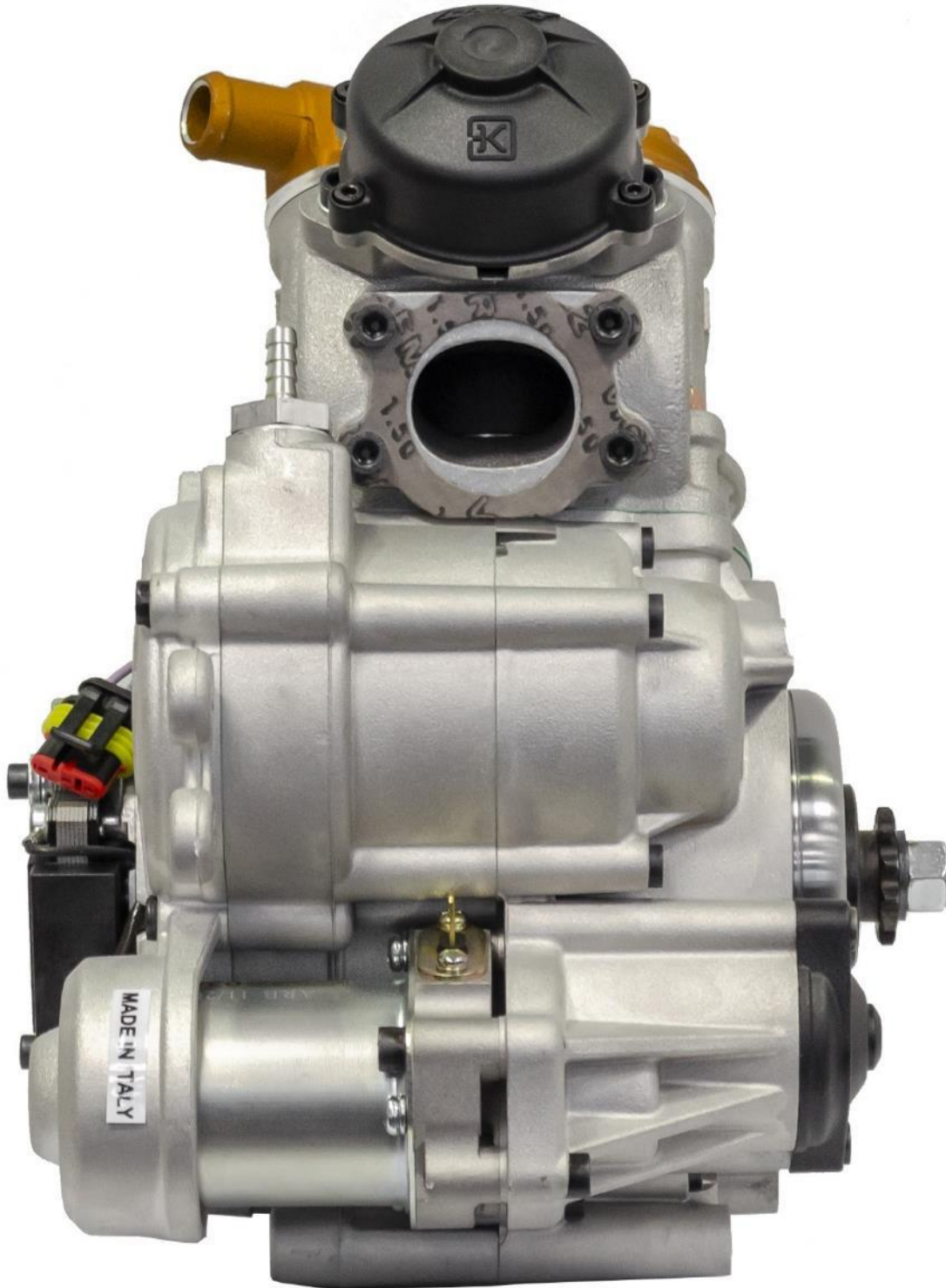



**PHOTO OF OPPOSITE DRIVE SIDE OF THE COMPLETE ENGINE**



**PHOTO OF THE REAR OF THE COMPLETE ENGINE**



**PHOTO OF THE FRONT OF THE COMPLETE ENGINE**





**PHOTO OF THE COMPLETE ENGINE TAKEN FROM ABOVE**



**PHOTO OF THE COMPLETE ENGINE TAKEN FROM BELOW**



## TECHNICAL INFORMATION

### A CHARACTERISTICS

<i>The number of decimal places must be 2 or comply with the relevant tolerance.</i>		<i>Tolerances &amp; remarks</i>
<b>Cylinder</b>		
<i>Volume of cylinder</i>	<b><u>123,99 cm<sup>3</sup></u></b>	<b>&lt;125cm<sup>3</sup></b>
<i>Original bore</i>	<b><u>54,07 mm</u></b>	--
<i>Theoretical maximum bore</i>	<b><u>54,28 mm</u></b>	--
<i>Original Stroke</i>	<b><u>54 mm</u></b>	+/-0,2mm
<b>Crankshaft</b>		
<i>Number of transfer ducts, cylinder/sump</i>	<b><u>5 / 3</u></b>	--
<i>Number of exhaust ports / ducts</i>	<b><u>1 + 2 BOOSTER</u></b>	--
<i>Volume of the combustion chamber</i> <small>Measured at thr top edge of the CIK/FIA insert.</small>	<b><u>9,5 cm<sup>3</sup></u></b>	minimum
<i>Volume of the combustion chamber in the cylinder head</i>	<b><u>Gauge</u></b>	--
<b>Balance Shaft</b>		
<i>Number of bearings</i>	<b><u>2</u></b>	--
<i>Diameter of bearings</i>	<b><u>62X30X16</u></b>	--
<i>Minimum weight of crankshaft</i> <small>All parts represented on page 19 photo</small>	<b><u>2,165g</u></b>	minimum
<b>Connecting Rod</b>		
<i>Minimum weight of balance shaft</i>	<b><u>430g</u></b>	minimum
<i>Percentage of balancing</i>	<b><u>    %    </u></b>	minimum
<i>Connecting rod centreline</i>	<b><u>102 mm</u></b>	±0.2mm
<i>Diameter of big end</i>	<b><u>26 mm</u></b>	±0.02mm
<i>Diameter of small end</i>	<b><u>18 mm</u></b>	±0.02mm
<i>Min. weight of the connecting rod</i>	<b><u>126 g</u></b>	minimum





D

**PHOTOS, DRAWINGS & GRAPHS**

**D.1 CYLINDER UNIT**

*EXPLODED DRAWING OF THE CYLINDER, CYLINDER HEAD AND EXHAUST MANIFOLD UNIT*

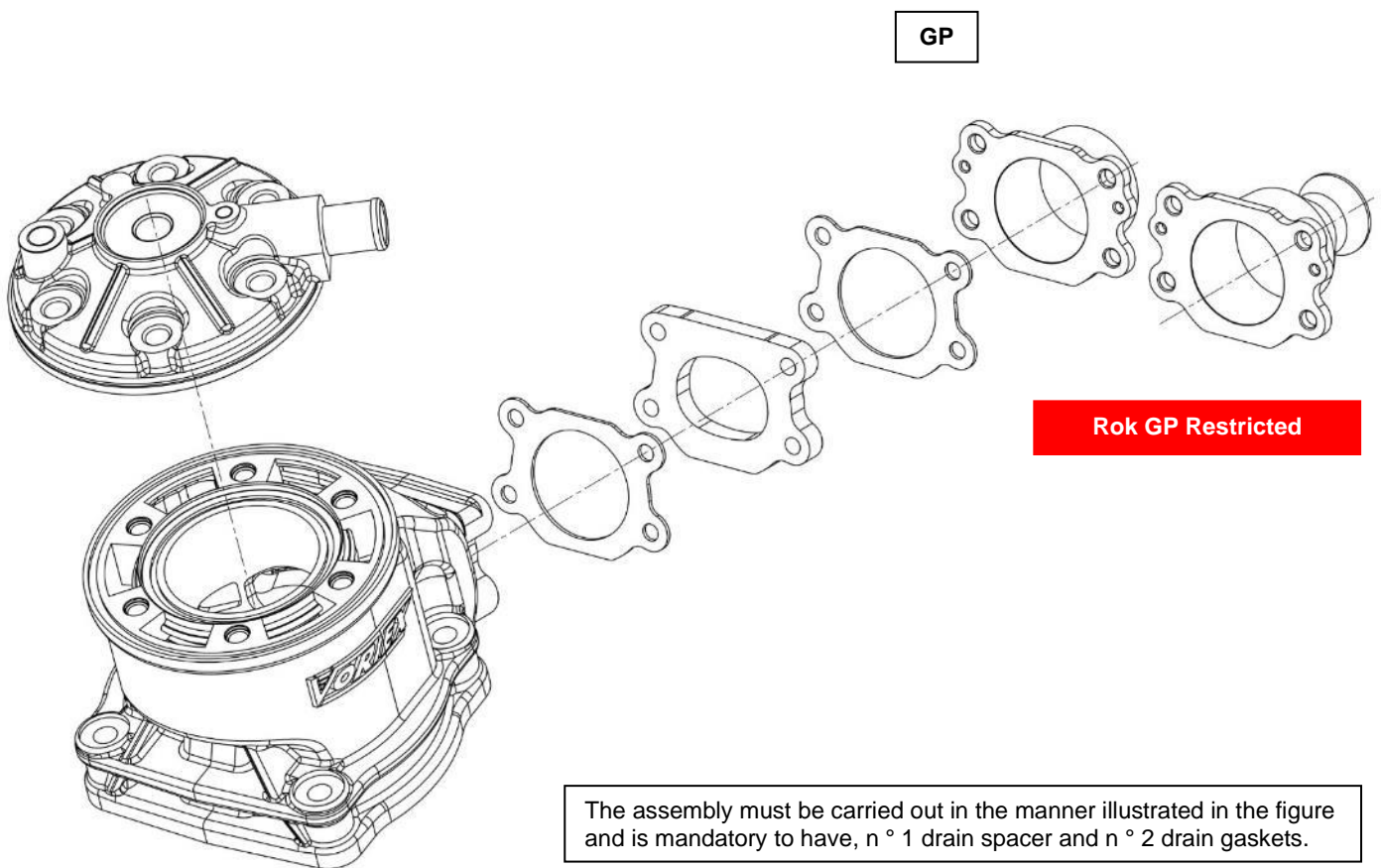

***Without screws or gaskets.***

***The aim of the exploded drawings is to identify the principles, the functioning and the whole mechanical unit***

... Section D.1

*DRAWING OF THE CYLINDER DEVELOPMENT*

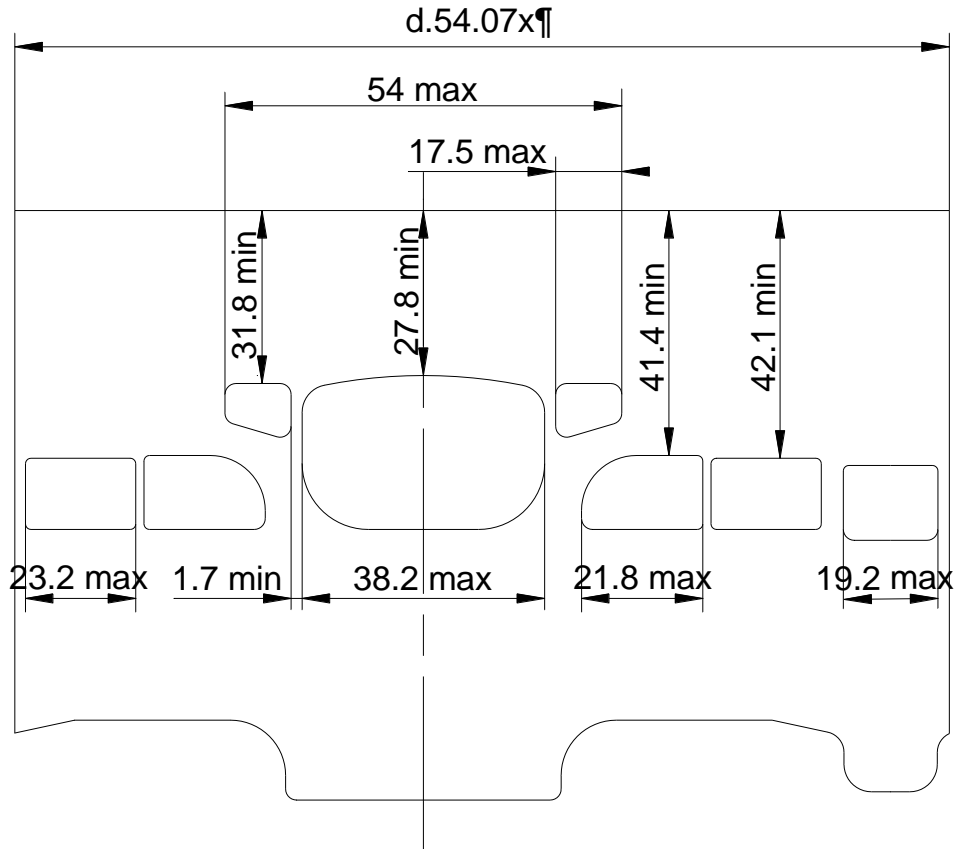

EXHAUST PORT	195° MAX
BOOSTER	180° MAX
MAIN TRANSFER	132° ±1.5°
SECONDARY TRANSFER	128° ±1.5°

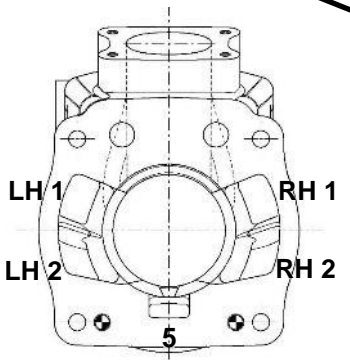
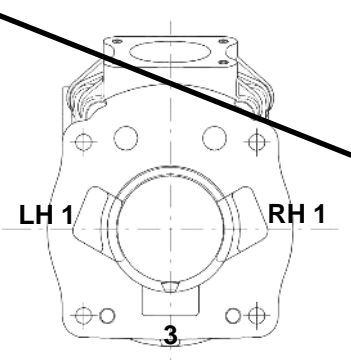

... Section D.1

<b>TRANSFER DUCTS VOLUME</b>			
<i>Transfer position on 5-transfer cylinder</i>	<i>Transfer position on 3-transfer cylinder</i>	<b>TRANSFER No.</b>	<b>VOLUME in cm<sup>3</sup></b>
		<i>Transfer No. 1 LH</i>	--... +/- 5 %
		<i>Transfer No. 2 LH</i>	--... +/- 5 %
		<i>Transfer No. 3 or 5</i>	--... +/- 8 %
		<i>Transfer No. 2 RH</i>	--... +/- 5 %
		<i>Transfer No. 1 RH</i>	--... +/- 5 %

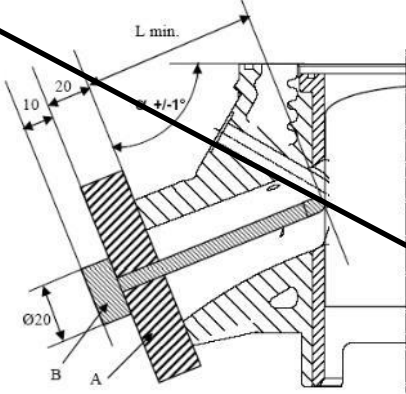
<b>EXHAUST DUCT LENGTH</b>		
	<b>ANGLE <math>\alpha</math> in °</b>	<b>Minimum in mm</b>
	--° +/-1°	-- mm
<b><i>The L min. dimension will be the result of the value taken on the reference engine minus 5 mm.</i></b>		
Technical Drawing No.13		
		
<ul style="list-style-type: none"> <li>A: Centring guide centred in relation to the exhaust duct by the exhaust manifold fixation screws, with a total thickness of 20 +/- 0.05 mm and being drilled in its centre by a hole with a 5 mm diameter, H7 bore.</li> <li>B: Control gauge composed of a shaft with a 5g6 diameter having a 2.5 mm radius at its end and a length = L min + 20+10.</li> </ul>		

... Section D.1

<b>INTERNAL PROFILE OF THE EXHAUST DUCT</b>
---

*Templates of the internal dimensions of the exhaust duct: gasket plane of the manifold.*

<b>FRONT VIEW DRAWING – WITH DIMENSIONS</b>
---

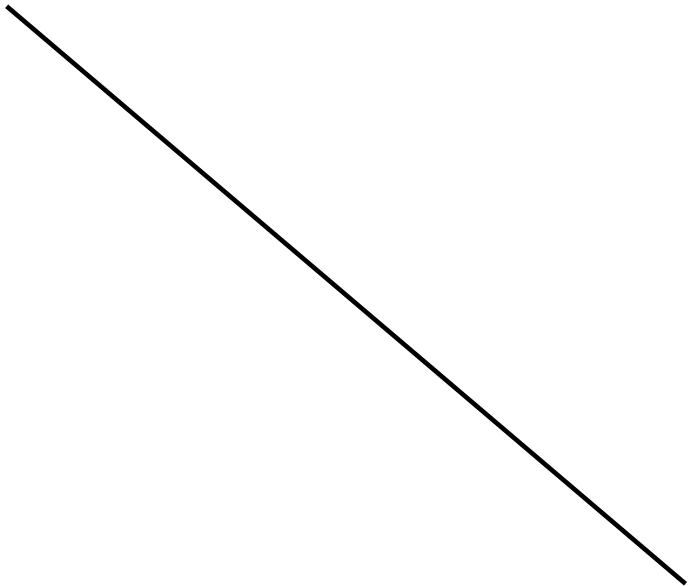
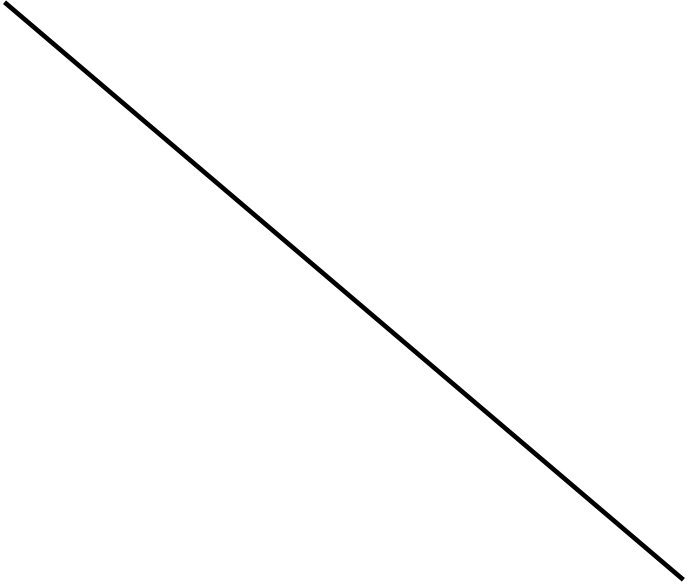
<i>Minimum template</i>	<i>Maximum template</i>
	

- *Maximum template: internal profile of the gasket plane of the manifold of the original cylinder plus 1 mm*
- *Minimum template: internal profile of the gasket plane of the manifold of the original cylinder minus 1 mm*
- *Thickness: 5 +/- 0,05 mm*

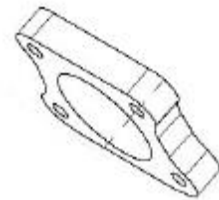

Technical Drawing No.13 bis

... Section D.1

DRAWING OF THE CYLINDER HEAD AND OF THE COMBUSTION CHAMBER with dimensions

SQUISH THICKNESS – SQUISH : 1mm Min.

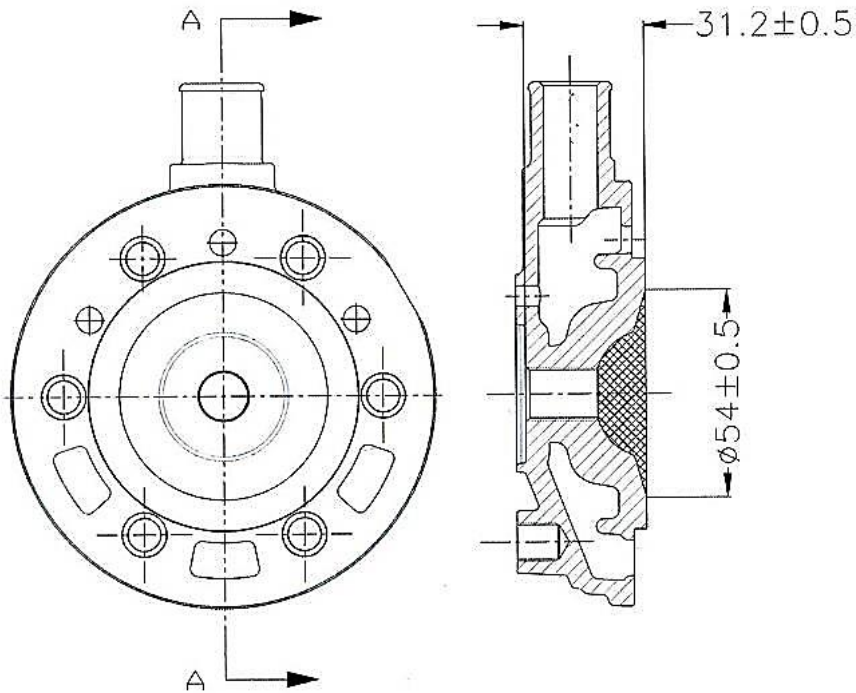

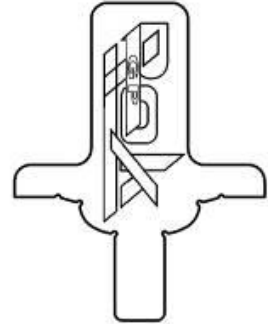

**TEMPLATE FOR  
CHECKING THE  
COMBUSTION  
CHAMBER PROFILE**



**Refer to Page 60 for  
compliance testing  
procedures.**



... Section D.1

PHOTO OF THE CYLINDER HEAD	PHOTO OF THE COMBUSTION CHAMBER IN THE CYLINDER HEAD
	

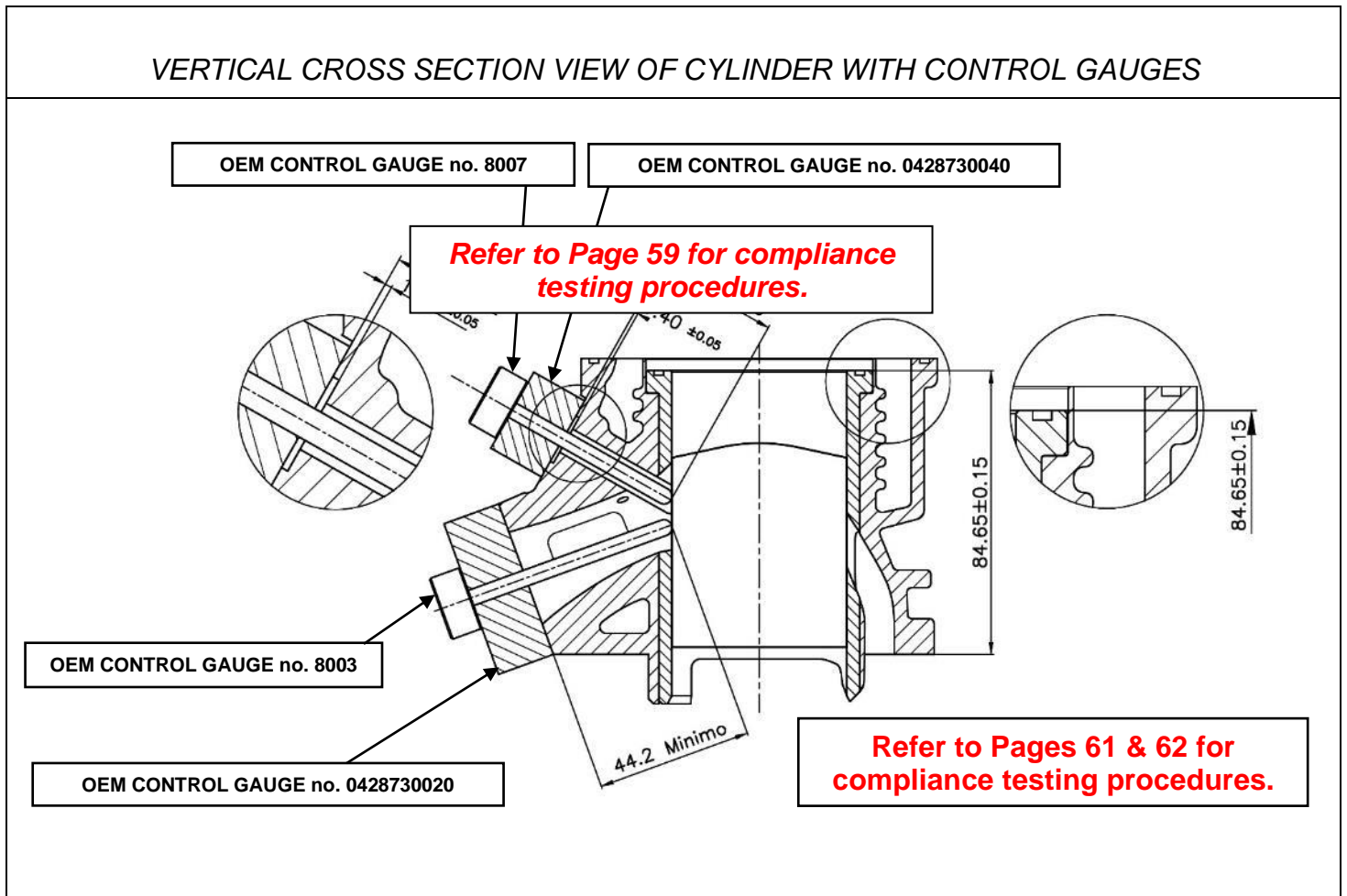

... Section D.1

*DRAWING OF THE CYLINDER BASE  
with dimensions*

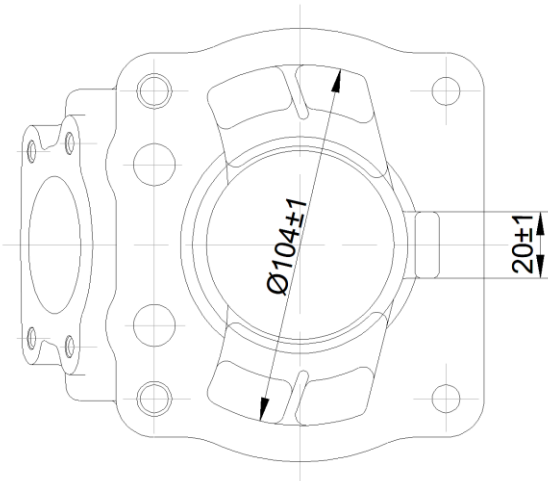

*PHOTO OF THE CYLINDER BASE*



*PHOTO OF THE CYLINDER FROM ABOVE*



*PHOTO OF THE CYLINDER FROM RH SIDE*

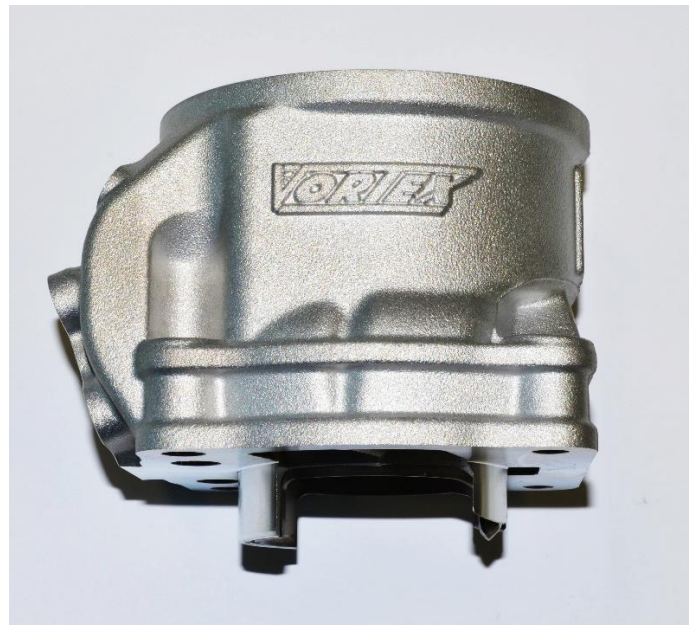

... Section D.1

*INTERNAL PROFILE OF THE EXHAUST DUCT*

*DRAWING – WITH DIMENSIONS*

*Rok GP*

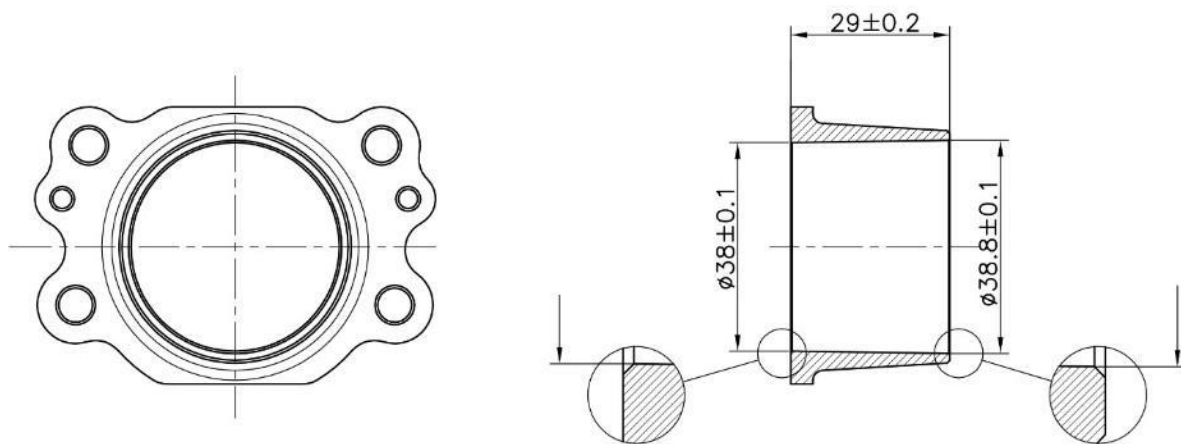

*Rok GP Restricted*

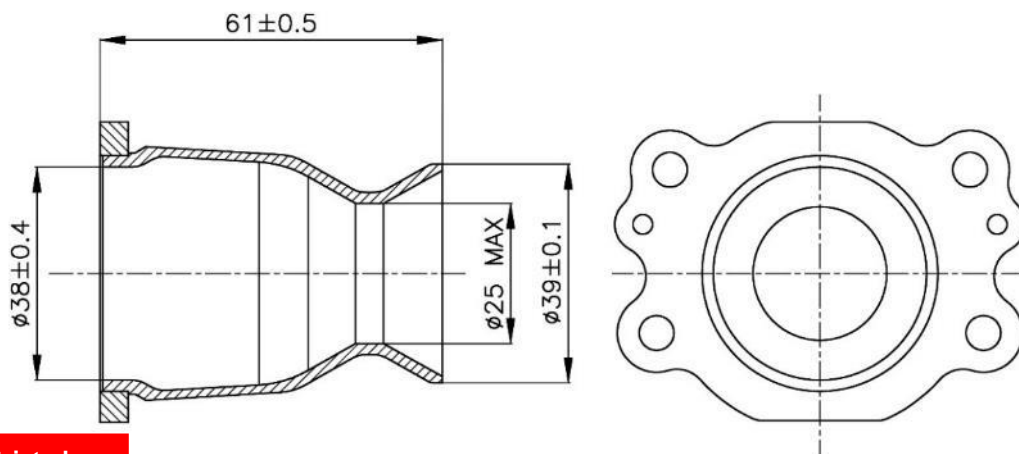

**Rok GP Restricted**

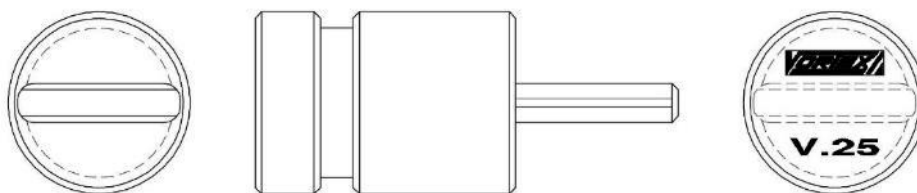

Checked with Vortex Template n° V.25  
**Refer to Page 63 for compliance testing procedures.**



... Section D.1

*EXHAUST SPACER AND GASKET*

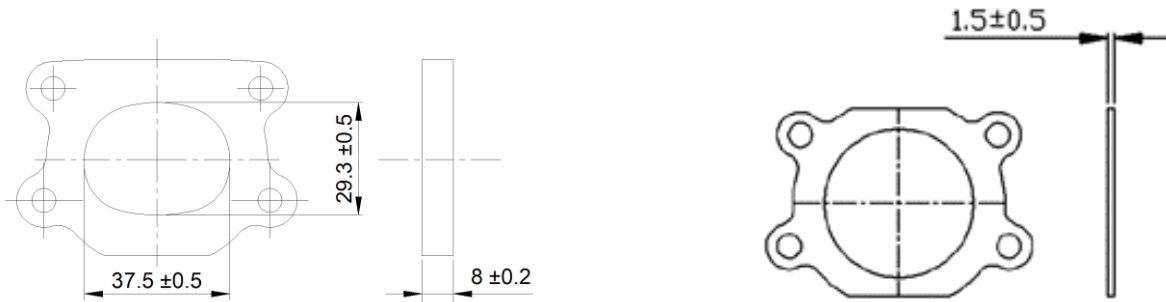

*PICTURES OF THE EXHAUST MANIFOLD*

*Rok GP*

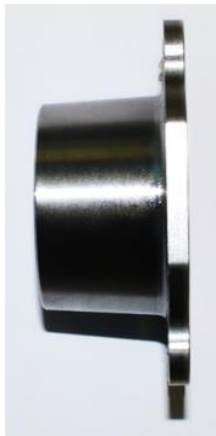

*Rok GP Restricted*



**Rok GP Restricted**

**D.2 CONROD, CRANKCASE, CRANKSHAFT & PISTON**

*EXPLODED DRAWING OF THE PISTON, CRANKSHAFT, CONNECTING ROD AND CRANKCASES UNIT (exploded crankshaft)*

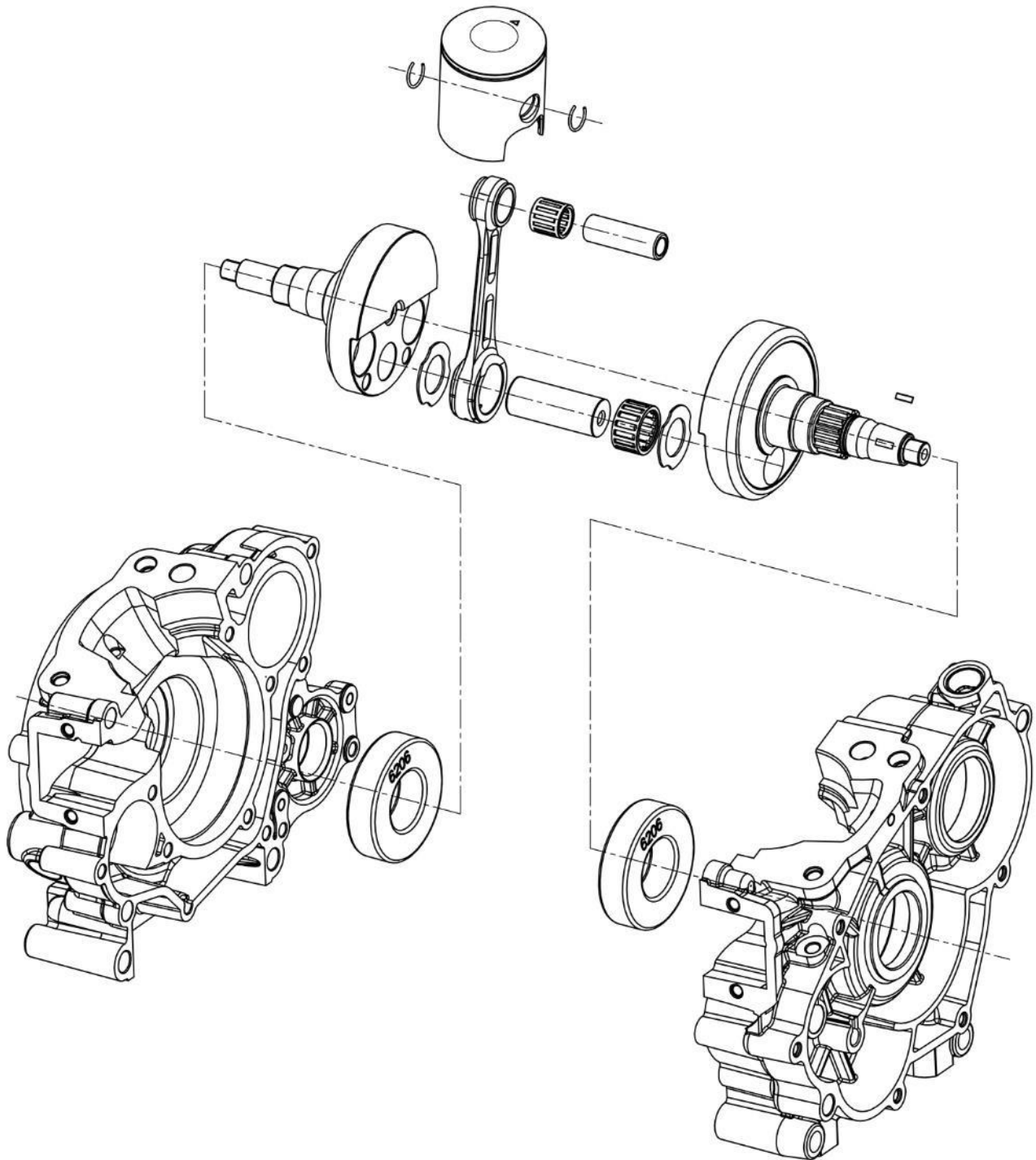

***Without screws or gaskets.***

***The aim of the exploded drawings is to identify the principles, the functioning and the whole mechanical unit***

...Section D.2

PICTURE OF THE CRANKSHAFT & CONROD

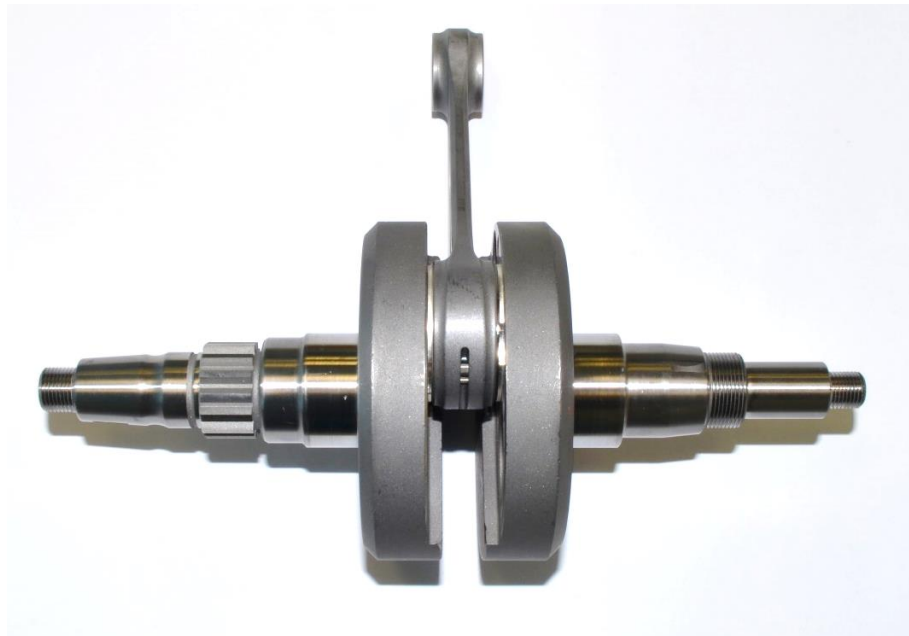

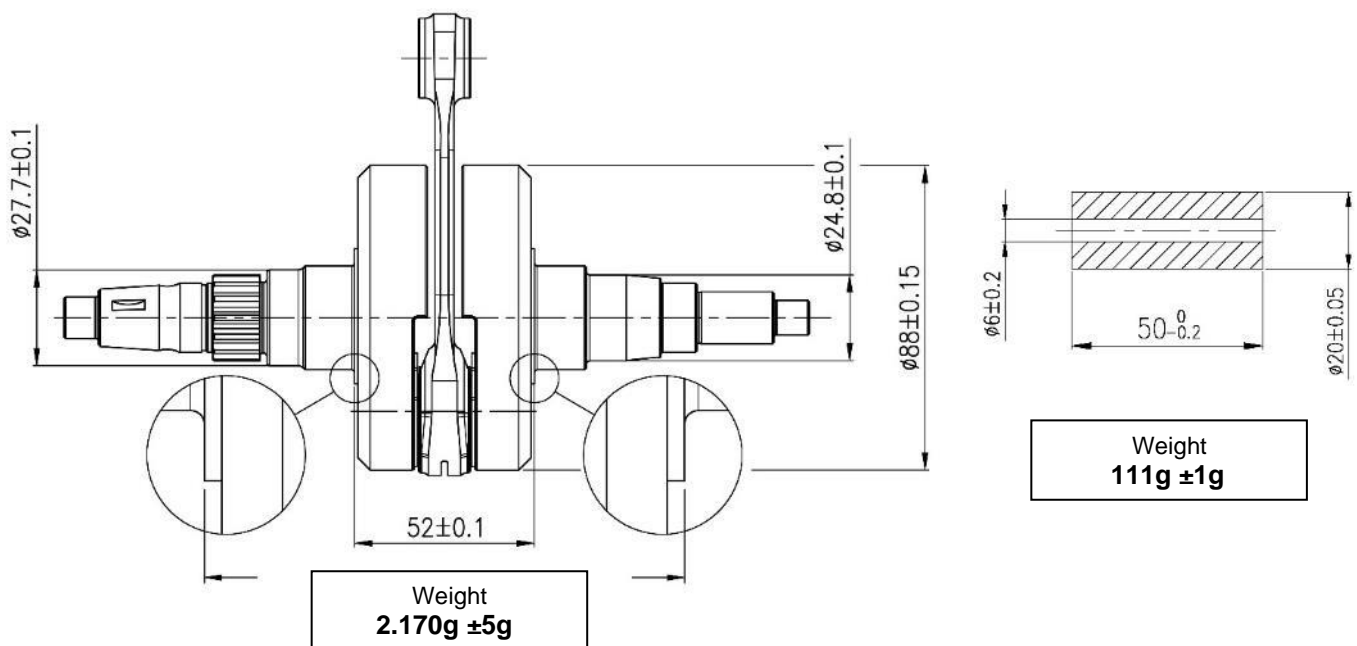

DRAWING OF THE CRANKSHAFT - CON ROD UNIT

(DIMENSIONS incl. tolerances, big & small ends thickness, crank mass thickness & diameter)

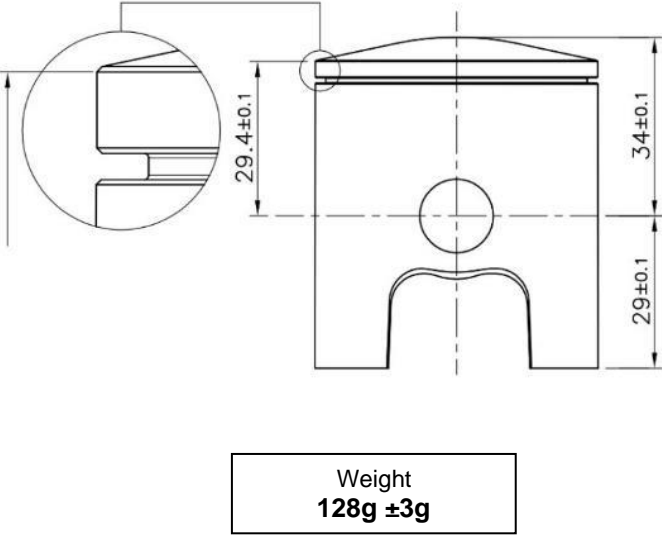
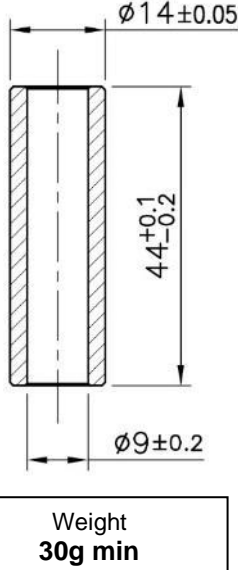

...Section D.2

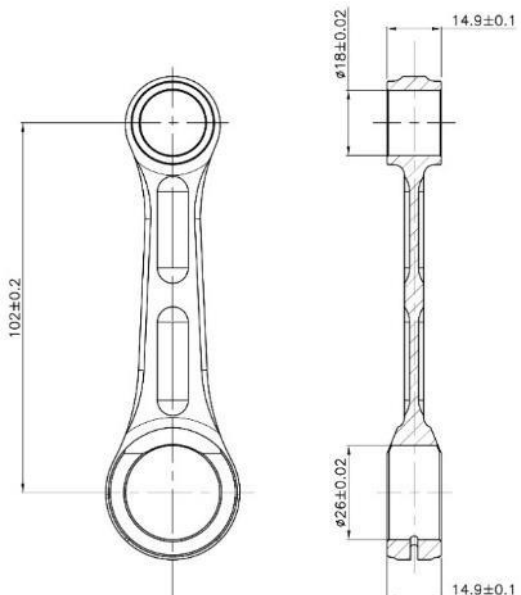
DRAWING OF THE PISTON (MAIN DIMENSIONS incl. tolerances)	DRAWING AND PHOTO OF THE CONROD
 <p>Weight <b>128g ±3g</b></p>	 <p>Weight <b>30g min</b></p>

DRAWING OF THE CONROD (MAIN DIMENSIONS incl. tolerances)	PICTURES OF THE CONROD
	



...Section D.2

PICTURE OF THE INSIDE OF THE RH  
CRANKCASE

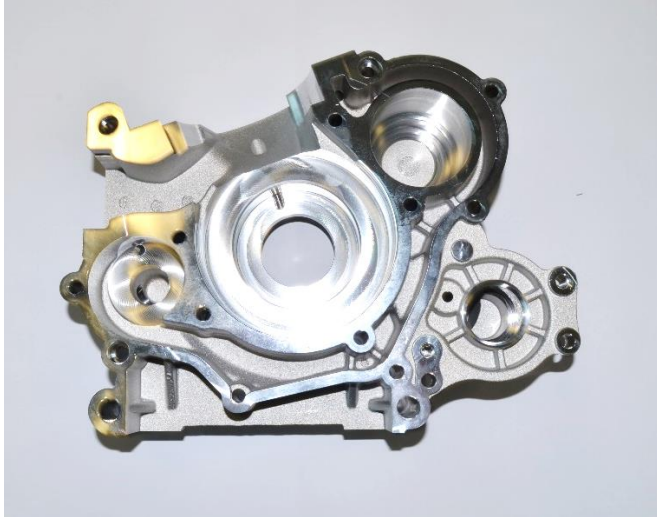

PICTURE OF THE INSIDE OF THE LH  
CRANKCASE



DRAWING OF THE CRANKCASE WITH DIMENSION

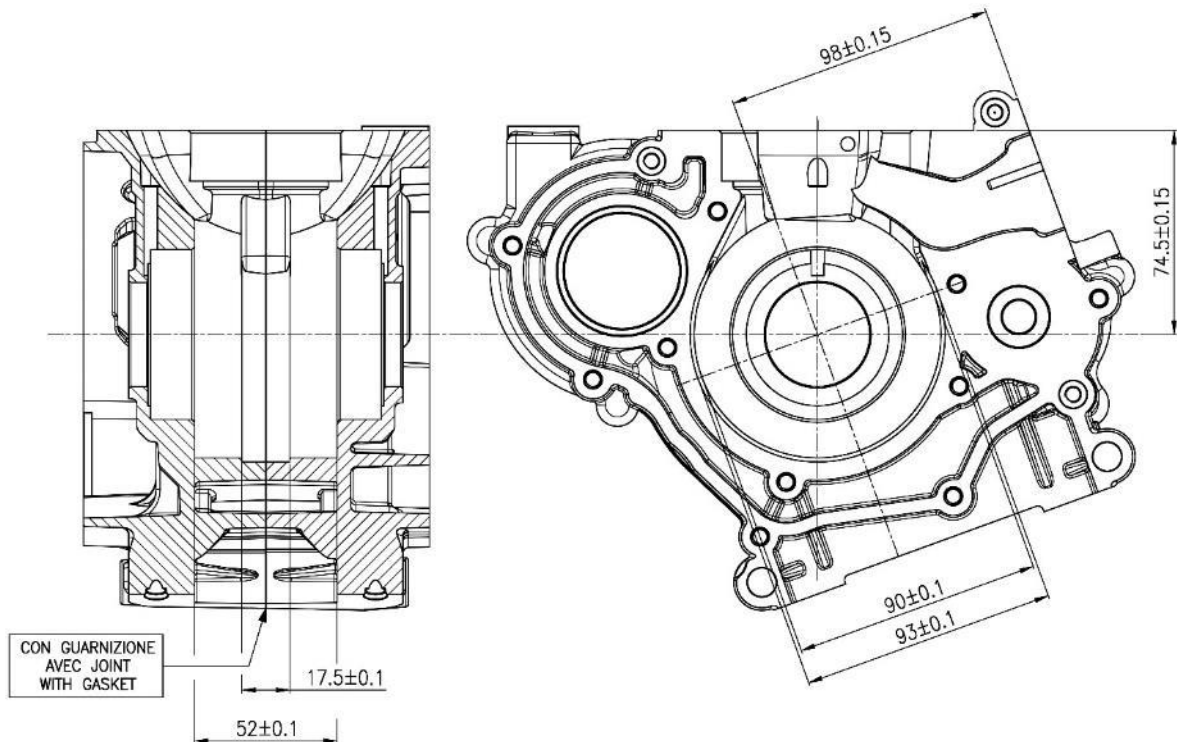

**...Section D.2**

<i>CRANKCASE BEARINGS</i>		
<i>TYPE</i>	<i>DIMENSIONS</i>	<i>FEATURES</i>
<i>Free brand <b>6206.C4</b></i>	<i>30 x 16 x 62 mm</i>	<i>Steel balls <b>9</b></i>
<i>BALANCE SHAFT BEARINGS</i>		
<i>TYPE</i>	<i>DIMENSIONS</i>	<i>FEATURES</i>
<i>Free brand <b>6005.C4</b></i>	<i>25 x 12 x 47 mm</i>	<i>Steel balls <b>10</b></i>
<i>Free brand <b>6302.C4</b></i>	<i>15 x 13 x 42 mm</i>	<i>Steel balls <b>7</b></i>

### **D.3 BALANCE SHAFT**

*EXPLODED DRAWING OF THE BALANCE SHAFT, WATER PUMP INCLUDING HOUSING*

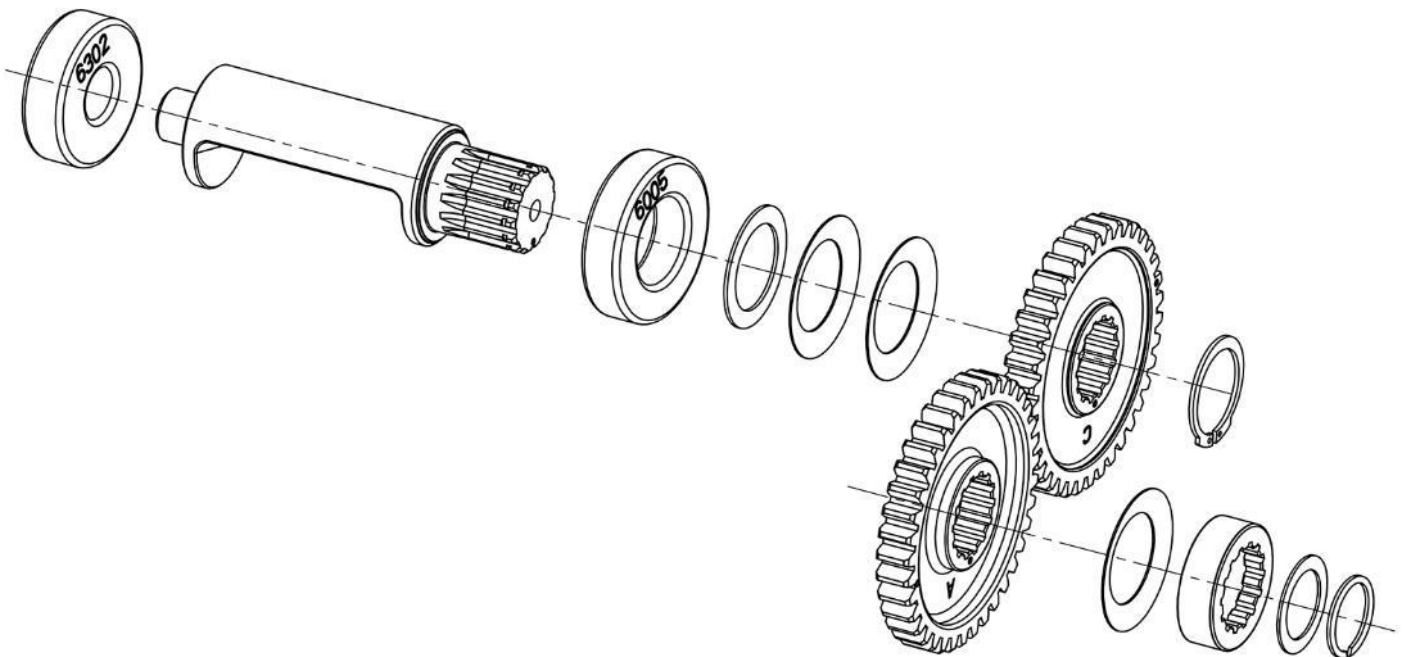

***Without screws or gaskets.***

***The aim of the exploded drawings is to identify the principles, the functioning and the whole mechanical unit***

...Section D.3

PHOTO OF THE BALANCE SHAFT



DRAWING OF THE BALANCE SHAFT  
(DIMENSIONS incl. tolerances)

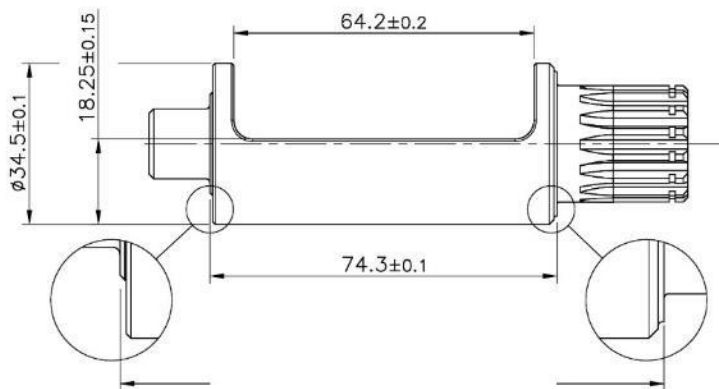

Weight  
**435g  $\pm 5g$**



...Section D.3

DRAWING OF THE BALANCE SHAFT PHASING

**BALANCER SHAFT PHASING**

***In the drawing below, we show you in detail the original position (to be respected) of the balancer shaft phasing in the rok engine.***

***As the timing should be regular, the notchs of the gears and the balancer shaft should correspond when the piston is at the dead upper point. As showed on the drawing.***

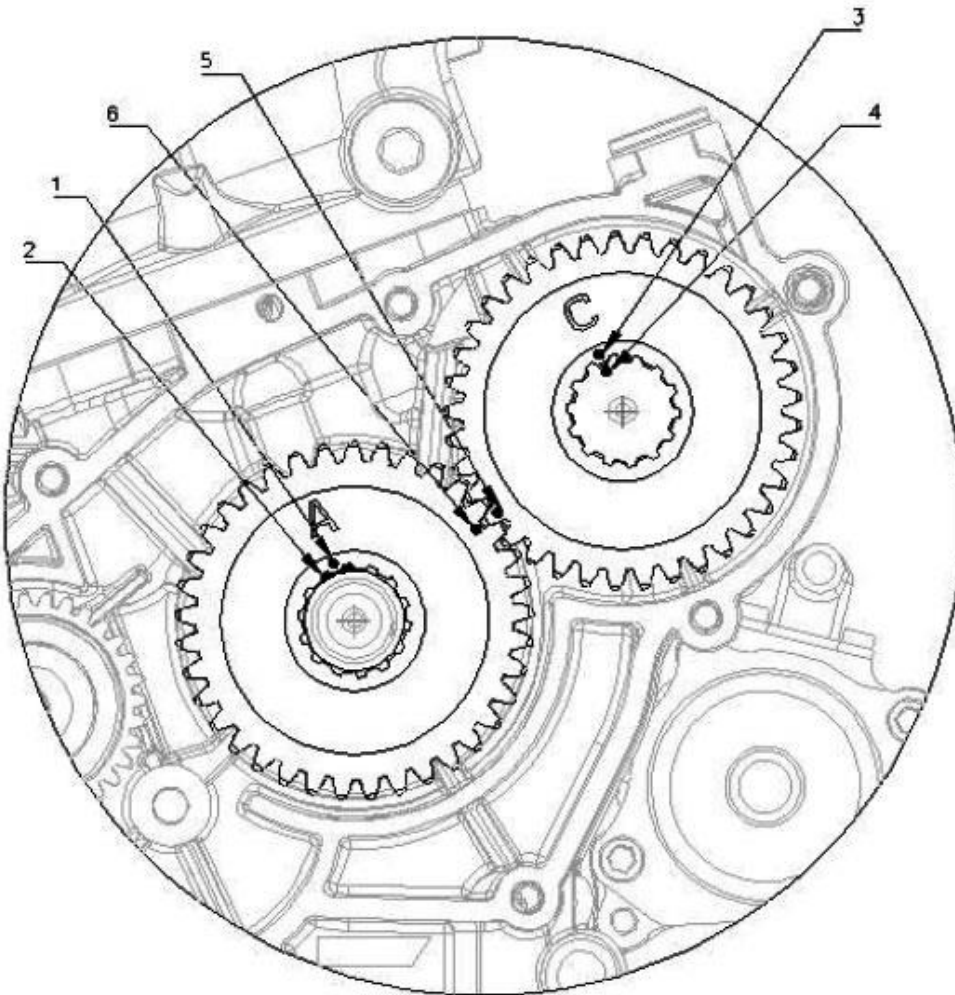

#### **D.4 REED VALVE & CLUTCH**

### *TECHNICAL DRAWING (exploded view) OF THE REED VALVE*

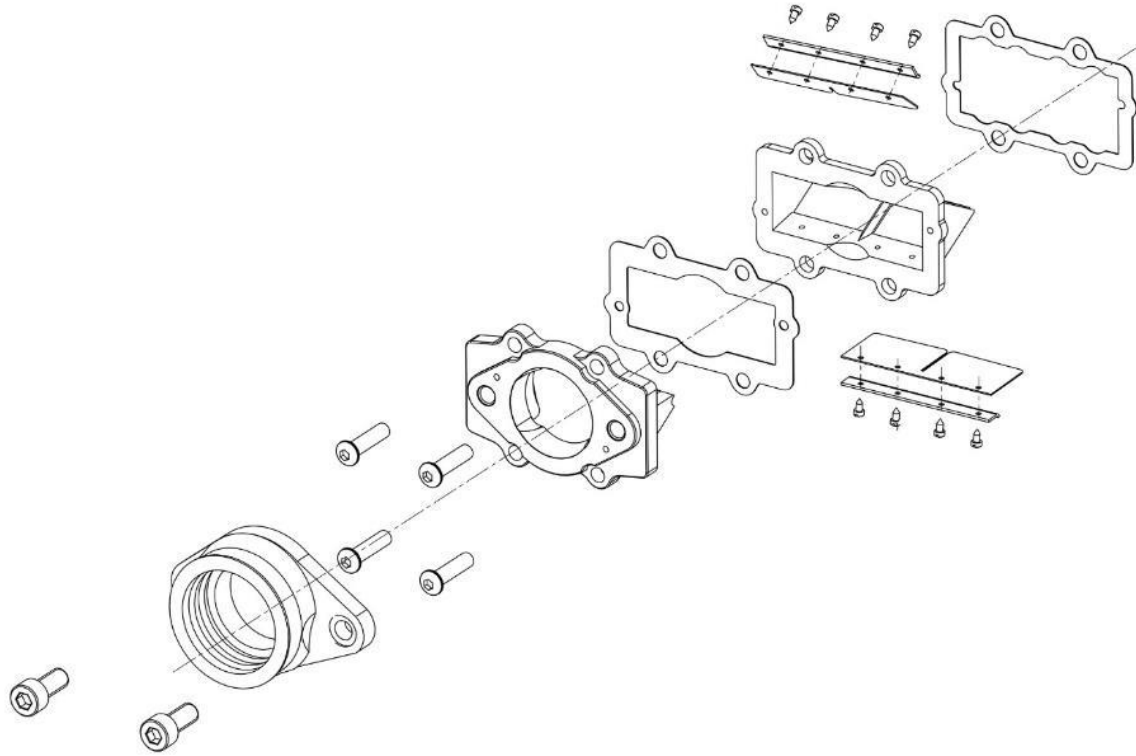

***The aim of the exploded drawings is to identify the principles, the functioning and the whole mechanical unit***

... Section D.4

**DRAWING OF THE REED VALVE SUPPORT**  
(DIMENSIONS incl. **tolerances**)

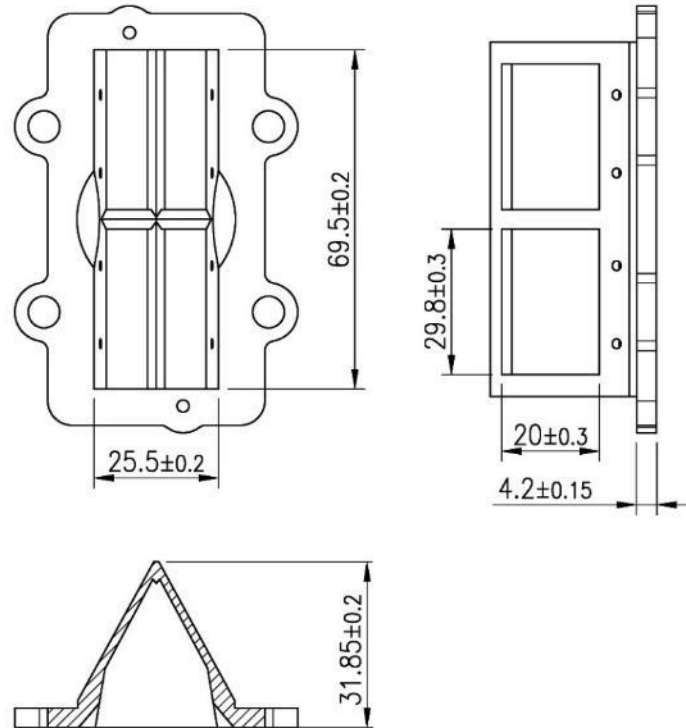

**DRAWING OF THE REED VALVE INLET**  
(DIMENSIONS incl. **tolerances**)

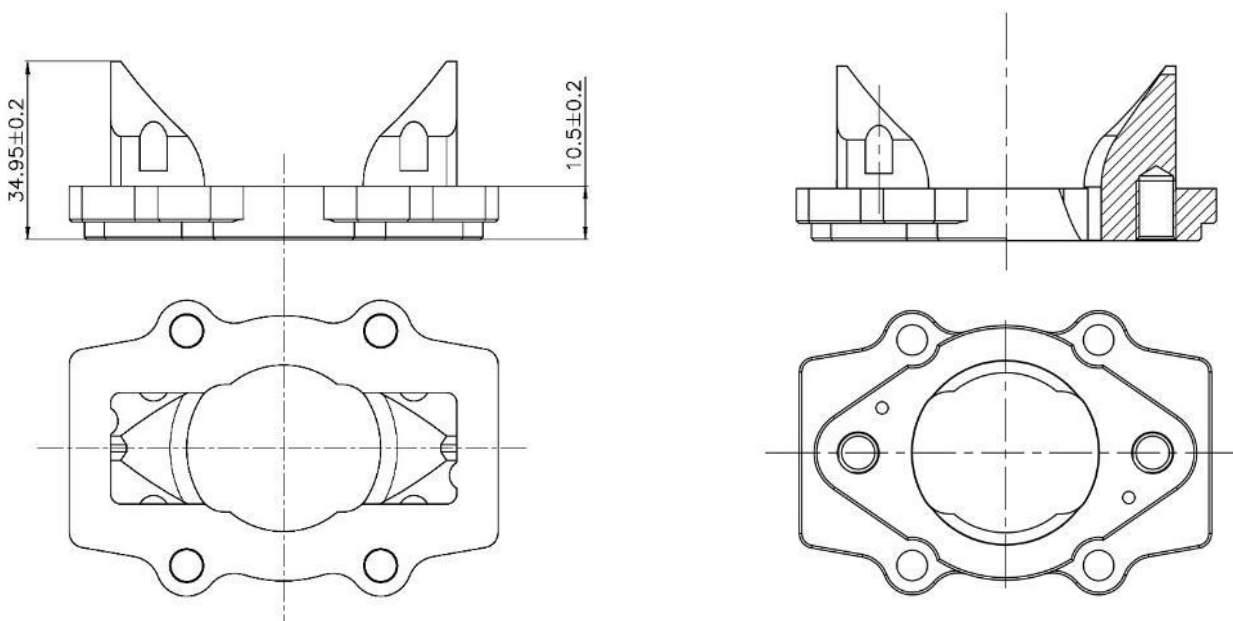

... Section D.4

DRAWING OF THE INTAKE MANIFOLD  
(DIMENSIONS incl. **tolerances**)

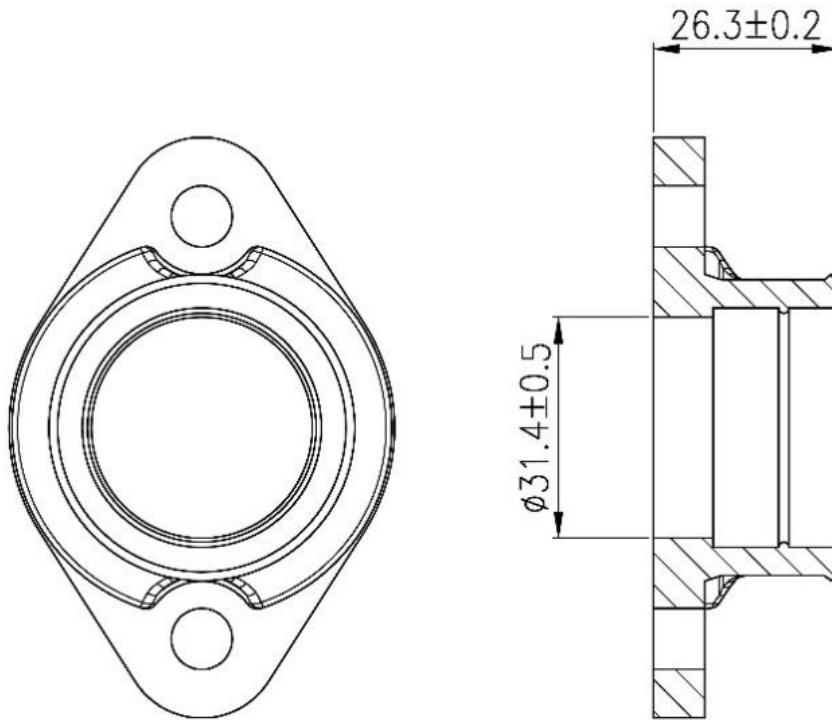



... Section D.4

*TECHNICAL DRAWING (exploded view) OF THE CLUTCH ASSEMBLY*

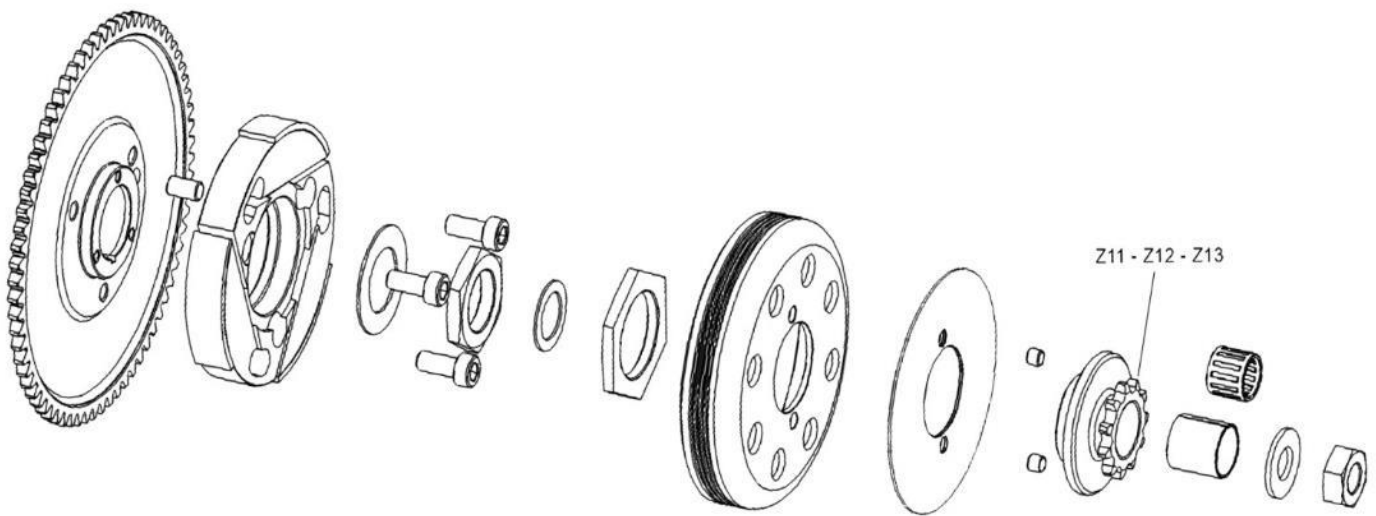

**PARTS QUANTITY : 19**

**WEIGHT OF COMPLETE CLUTCH WITH STARTING GEAR AND PROTECTION: 938 gr +/- 15g**

**ENGAGEMENT SPEED (MAXIMUM) CAN BE VERIFIED IN EVERY MOMENT OF THE EVENT: 4000 RPM**

... Section D.4

**TECHNICAL DRAWING OF THE CLUTCH HOUSING AND CLUTCH ROTOR**  
(DIMENSIONS incl. tolerances)

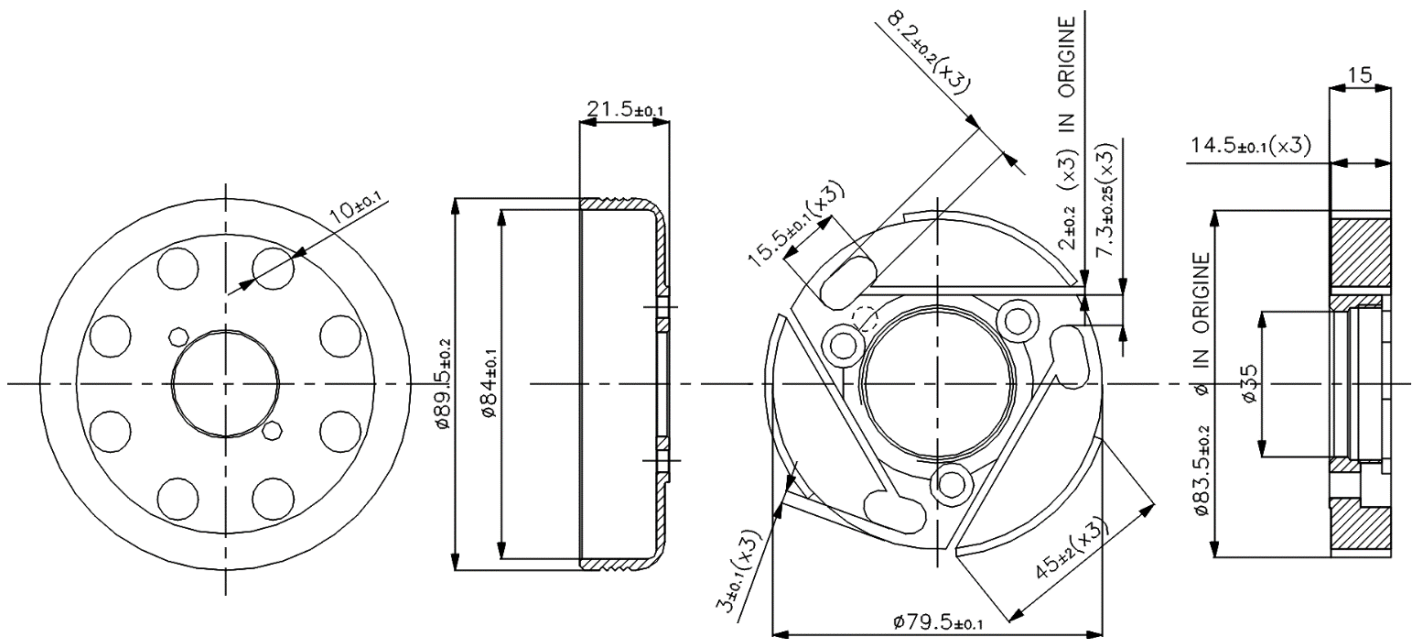

**WEIGHT OF CLUTCH ROTOR: 356 gr +/- 10g**

**WEIGHT OF CLUTCH HOUSING: 184 gr +/- 5g**

**D.5 EXHAUST SYSTEM**

PICTURES OF THE EXHAUST MANIFOLD

*Rok GP*

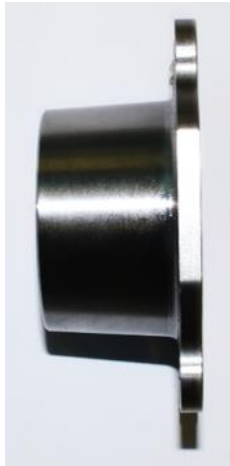

*Rok GP Restricted*



**Rok GP Restricted**

PICTURE OF THE EXHAUST



... Section D.5

TECHNICAL DESCRIPTIONS  
OF THE EXHAUST (Art. 8.9.3 of HR)

Weight in g	2,045	Minimum
-------------	-------	---------

EXHAUST TECHNICAL DRAWING

*It must include all the information necessary to build this exhaust.*

EXTERNAL CHORD READING : **A=850+/-7mm**

INTERNAL CHORD READING: **B=680+/-7mm**

NUMBER OF HOLES: **C = 56**  $\phi$  **4±0.5**

WEIGHT: **2.158 g. ± 5%**

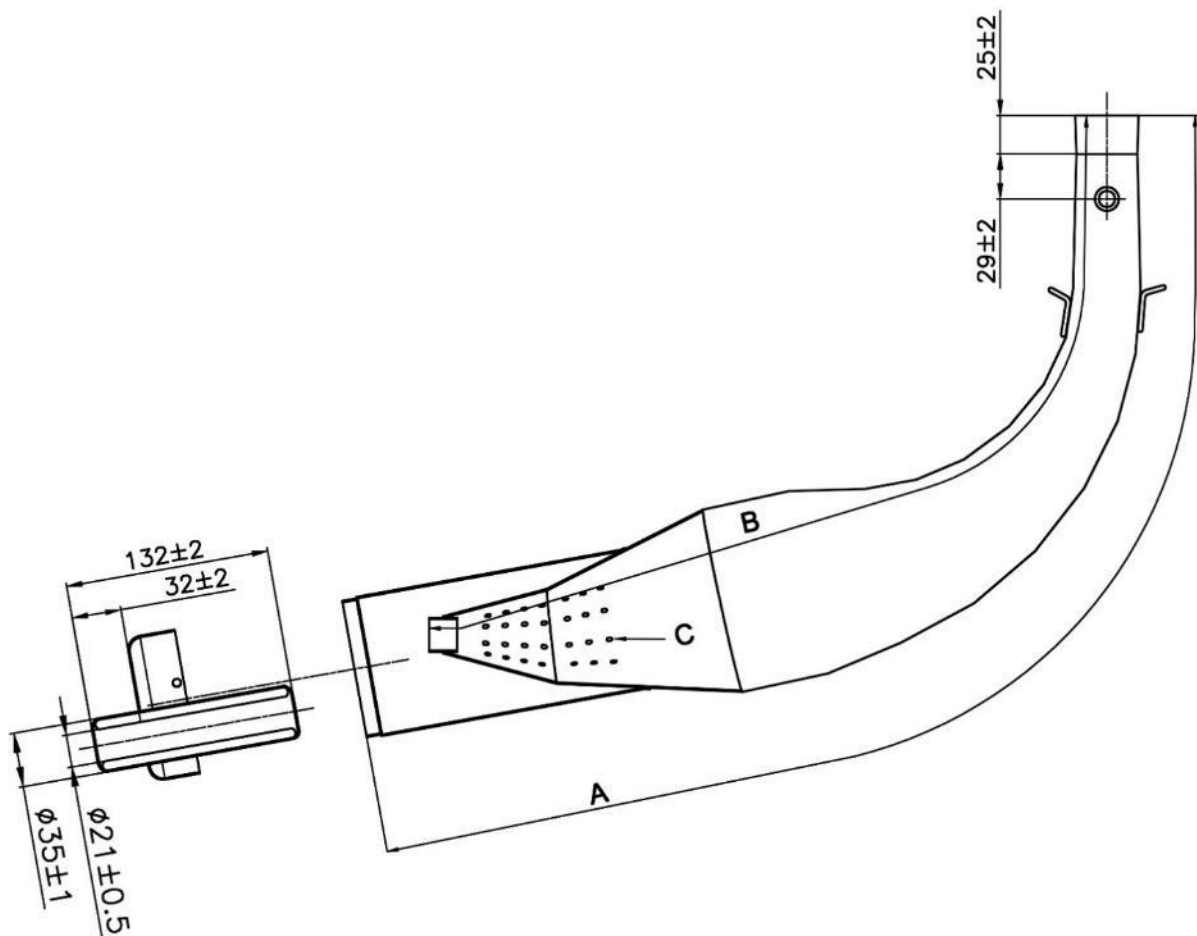



... Section D.5

**EXPLODED DRAWING AND DESIGNATION OF THE POWER VALVE COMPONENTS**

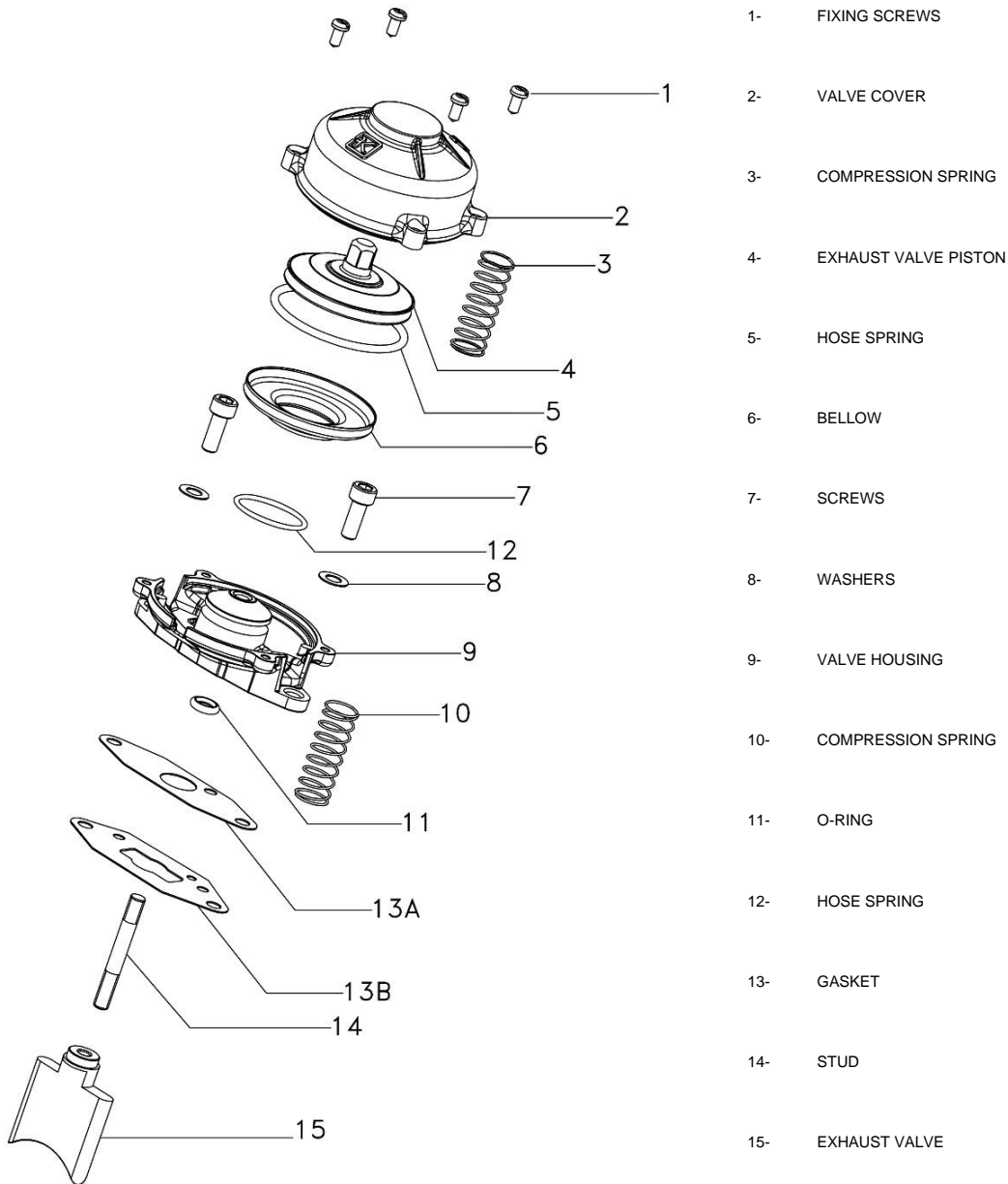

**The aim of the exploded drawings is to identify the principles, the functioning and the whole mechanical unit**

**D.6 STARTER**

*EXPLODED DRAWING OF THE STARTING UNIT AND OF ITS HOUSING*

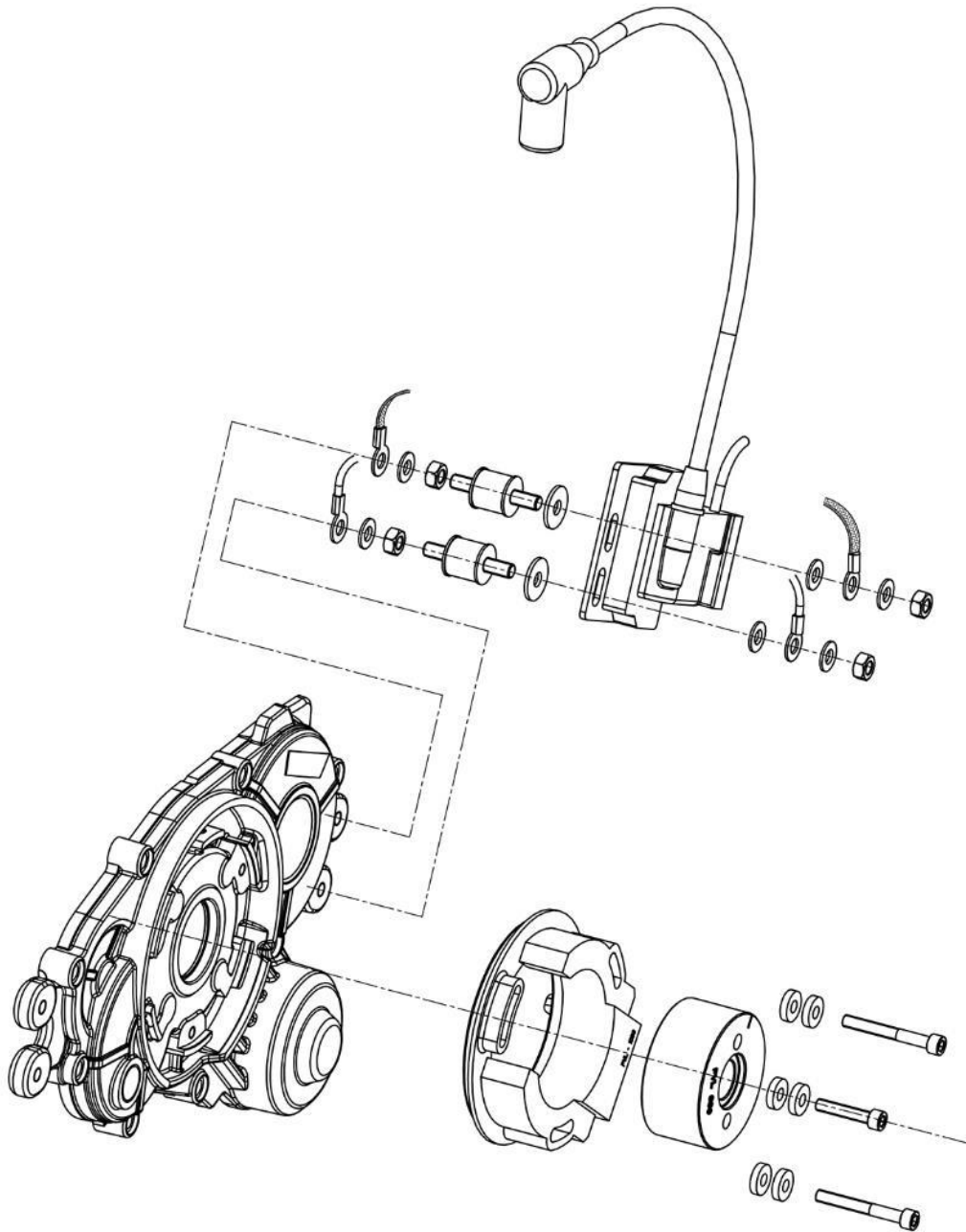

... Section D.6

EXPLODED DRAWING OF THE STARTING UNIT AND OF ITS HOUSING

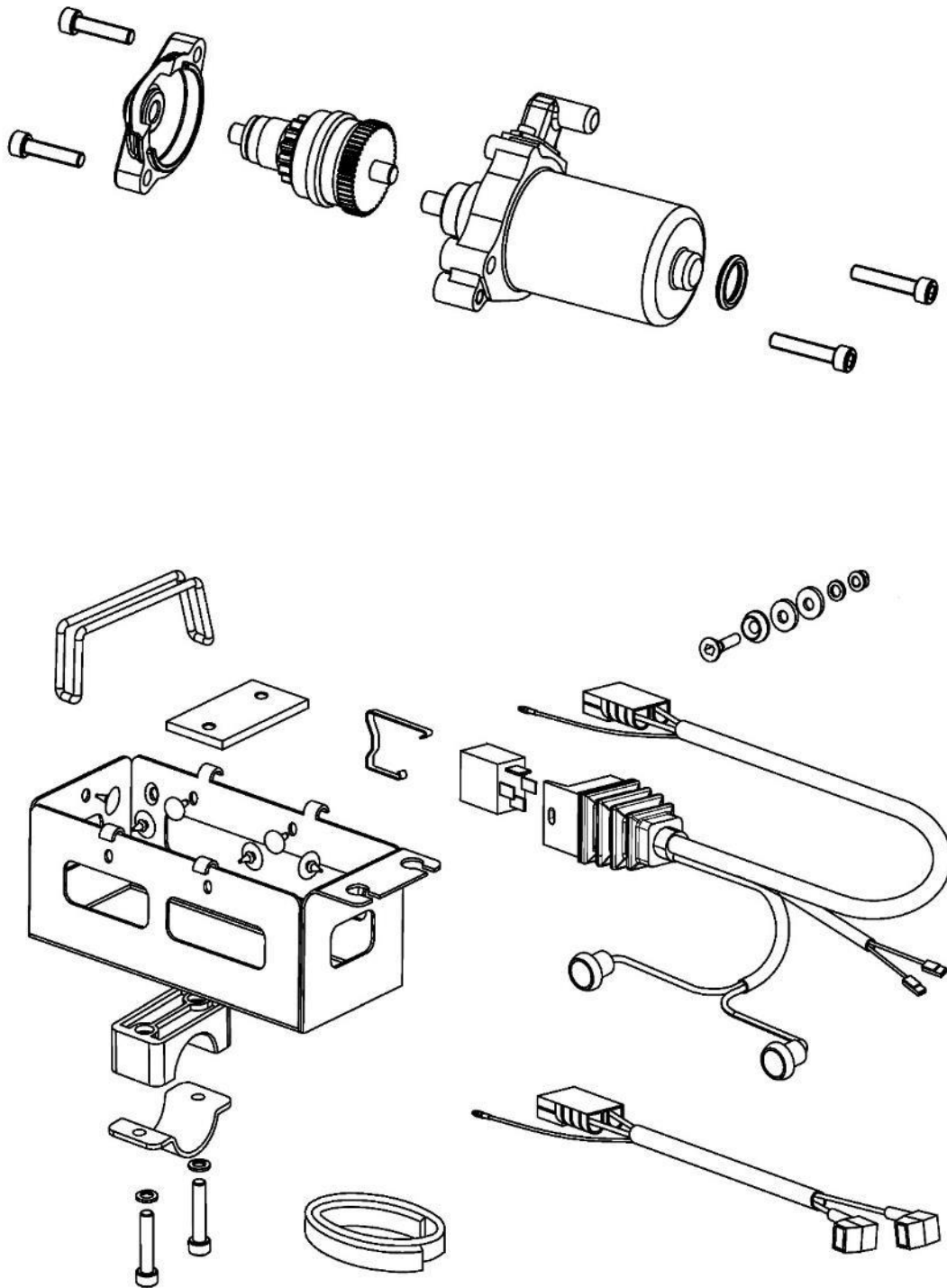

... Section D.6

PICTURES OF THE STARTING UNIT AND OF ITS HOUSING



***The Engine must switched on and off by means of onboard starting system.***

Technical Officials shall check the on-off onboard system at any time in accordance with the Rules.

**D.6 ELECTRICAL SYSTEM**

*IGNITION SYSTEM PVL (Option 1)  
500 212*





...Section D.6

ADVANCE CURVE GRAPHS

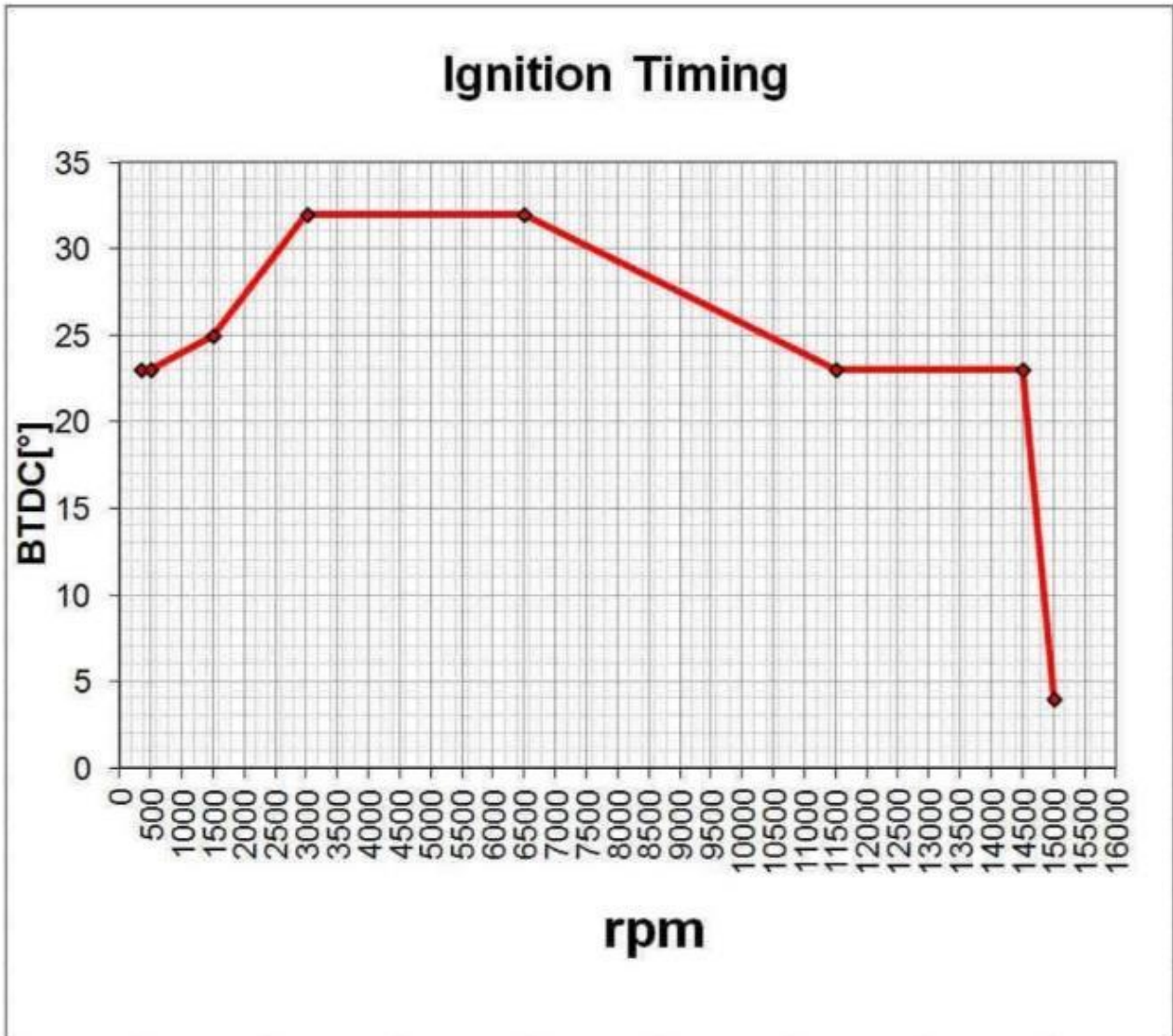

<i>Ignition homologation No.</i>														
<i>Ignition homologation No.</i>														
<i>Ignition homologation No.</i>														
<i>Ignition homologation No.</i>														
Code		<b>F125 --/M/18</b>										<i>Color yellow</i>		
Tr/min	1000	2000	3000	4000	5000	6000	7000	8000	9000	10000	11000	12000	13000	14000
° adv														

...Section D.6

IGNITION SYSTEM SELETTA (Option 2)  
034-IG-14 P3356  
03014560 50528/51.20 ROK

**USE OF COILS MARKED WILL BE ALLOWED, AS MENTIONED IN THE ABOVE PICTURES.**







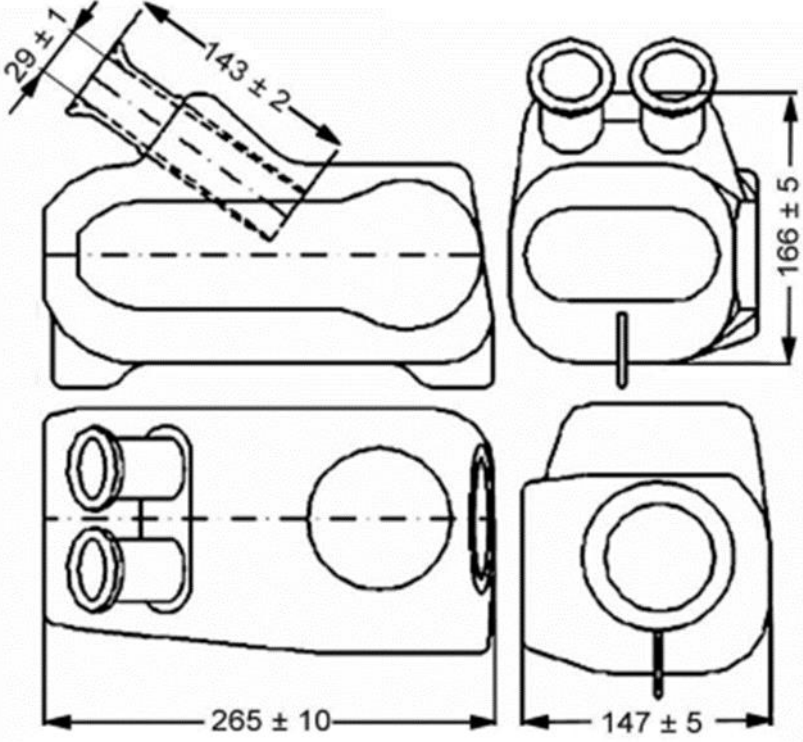

**D.7 AIR INTAKE SYSTEM**

**INLET SILENCER**

Model Type	Arrow (Dimensions and markings)
	 <p>It is not permitted to alter the dimensions of the inlet silencer.</p> <p>Marking </p>
<p>Permitted Modification</p>	<p>The only permitted modification is the drilling of a drain hole – maximum 8mm diameter at the front centre line and the lowest point of the intake silencer box.</p>



Air Filter	Part Number: WDVS1AF Colour: Blue Marking: DVS
------------	--



The DVS foam air filter (blue colour) must be fitted at all times. It must be free of damage and/or tears and must not be modified.

Vortex OEM Mesh Stone Guard	<p>Fitting of the Vortex OEM Stone Guard is optional.</p> 
-----------------------------	--

Rain Cover	The fitting of a rain cover (non-OEM) is optional.
------------	--



**D.8 CARBURETTOR AND FUEL PUMP**

**CARBURETTOR DELL'ORTO 30mm DIAMETER, AND COMPONENTS**

**DELL'ORTO VSHH 30**

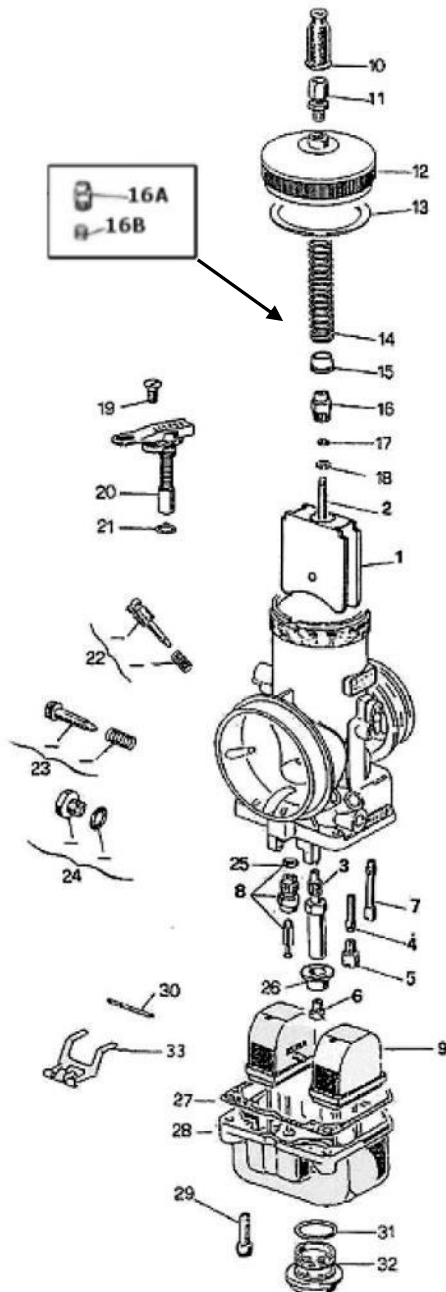

- |   |                              |
|---|------------------------------|
| 1. GUILLOTINE                                 | THROTTLE VALVE               |
| 2. AIGUILLE                                   | MIXTURE NEEDLE               |
| 3. PULVERISATEUR                              | SPARY NOZZLE                 |
| 4. EMULSEUR MINIMUM                           | IDLE DIFFUSER                |
| 5. GICLEUR MINIMUM                            | IDLE JET                     |
| 6. GICLEUR MAXIMUM                            | HIGH SPEED JET               |
| 7. GICLEUR DEMARRAGE                          | STARTER JET                  |
| 8. POINTEAU                                   | NEEDLE VALVE                 |
| 9. FLOTTEUR 4 gr. x 2                         | FLOATER 4 gr. x 2            |
| 10. MANCHON                                   | CAP                          |
| 11. VIS DE TENSION                            | WIRE SCREW                   |
| 12. COUVERCLE DU CORPS                        | BODY COVER                   |
| 13. JOINT COUVERCLE DE CHAMBRE                | COVER GASKET                 |
| 14. RESSORT DE RAPPEL GUILLOTINE<br>16A e 16B | THROTTLE VALVE RETURN SPRING |
| 15. ASSIETTE GUIDE RESSORT                    | SPRING GUIDE PLATE           |
| 16. NIPPLD VALVE GAZ                          | MIXTURE VALVE NIPPLE         |
| 17. RONDELLE                                  | WASHER                       |
| 18. ARRET DE L'AIGUILLE                       | MIXTURE NEEDLE STOP          |
| 19. VIS DU DISPOSITIF DE DEMARRAGE            | STARTER FIXING SCREW         |
| 20. DISPOSITIF DE DEMARRAGE                   | CHOKE                        |
| 21. JOINT DISPOSITIF DEMARRAGE                | STARTER GASKET               |
| 22. KIT VIS DE REGLAGE DE L'AIR               | KIT AIR ADJUSTMENT SCREW     |
| 23. KIT VIS DE REGLAGE GUILLOTINE             | KIT MIXTURE VALVE ADJUSTMENT |
| 24. BOUCHON FILTRE A ESSENCE                  | FUEL FILTER PLUG             |
| 25. JOINT DU POINTEAU                         | NEEDLE VALVE GASKET          |
| 26. ASSIETTE                                  | PLATE                        |
| 27. JOINT DE LA CUVE                          | FLOAT VALVE GASKET           |
| 28. CUVE                                      | FLOAT CHAMBER                |
| 29. VIS FIXAGE DE LA CUVE                     | FLOAT CHAMBER SCREW          |
| 30. AXE                                       | PIN                          |
| 31. JOINT DU BOUCHON DE CUVE                  | FLOAT CHAMBER PLUG GASKET    |
| 32. BOUCHON DE LA CUVE                        | FLOAT CHAMBER PLUG           |
| 33. BALANCIER                                 | FLOAT LEVER                  |

... Section D.8

PICTURES OF CARBURETTOR



... Section D.8

PICTURES OF CARBURETTOR



... Section D.8

**DELL'ORTO FUEL PUMP. COD. 11023**



**FUEL PUMP, PULSE LINE, FUEL LINES AND FUEL FILTER**

The OEM Dell 'Orto fuel pump and components as supplied by Vortex must be used.

- Only one (1) fuel pump is permitted to be used at any time.
- The fuel pump must be mounted to the engine using the OEM mounting bracket.
- It is permitted to use one (1) only fuel filter that may be mounted between the fuel tank and fuel pump.
- The maximum length of pulse line must be no longer than 200mm.
- All fuel lines must be continuous (one piece without restriction, spigots, junctions, taps and similar devices) apart from the fuel tank pick up, the fuel filter and the fuel pump, with the following exceptions:
  - i. It is optional to fit a "T" junction in the fuel line between the fuel pump and the carburettor and to run a return fuel line from the "T" junction back to the fuel tank fitted with appropriate barbed fitting.

**ONLY ALLOWED SETTING**

	CODE VORTEX	CODE DELLORTO
Gas valve	W947540-764	1656540-64
Mixture needle K33	W853033	0853033-08
Spray nozzle DP268	W12539268	12539268-28
Needle Valve 250 Needle valve 270	W8649250 W8649270	08649250 33 08649270 33
Spray seat nozzle	W1254100-28	1254100-28
High speed jet - <b>FREE</b>	W6413160	06413160-02
Idle Jet - 60	W1299560	1299560-02
Idle jet CD1	WW1053201	1053201



**D.9 COOLING SYSTEM AND WATER PUMP**

*COOLING SYSTEM, RADIATOR AND MOUNT*

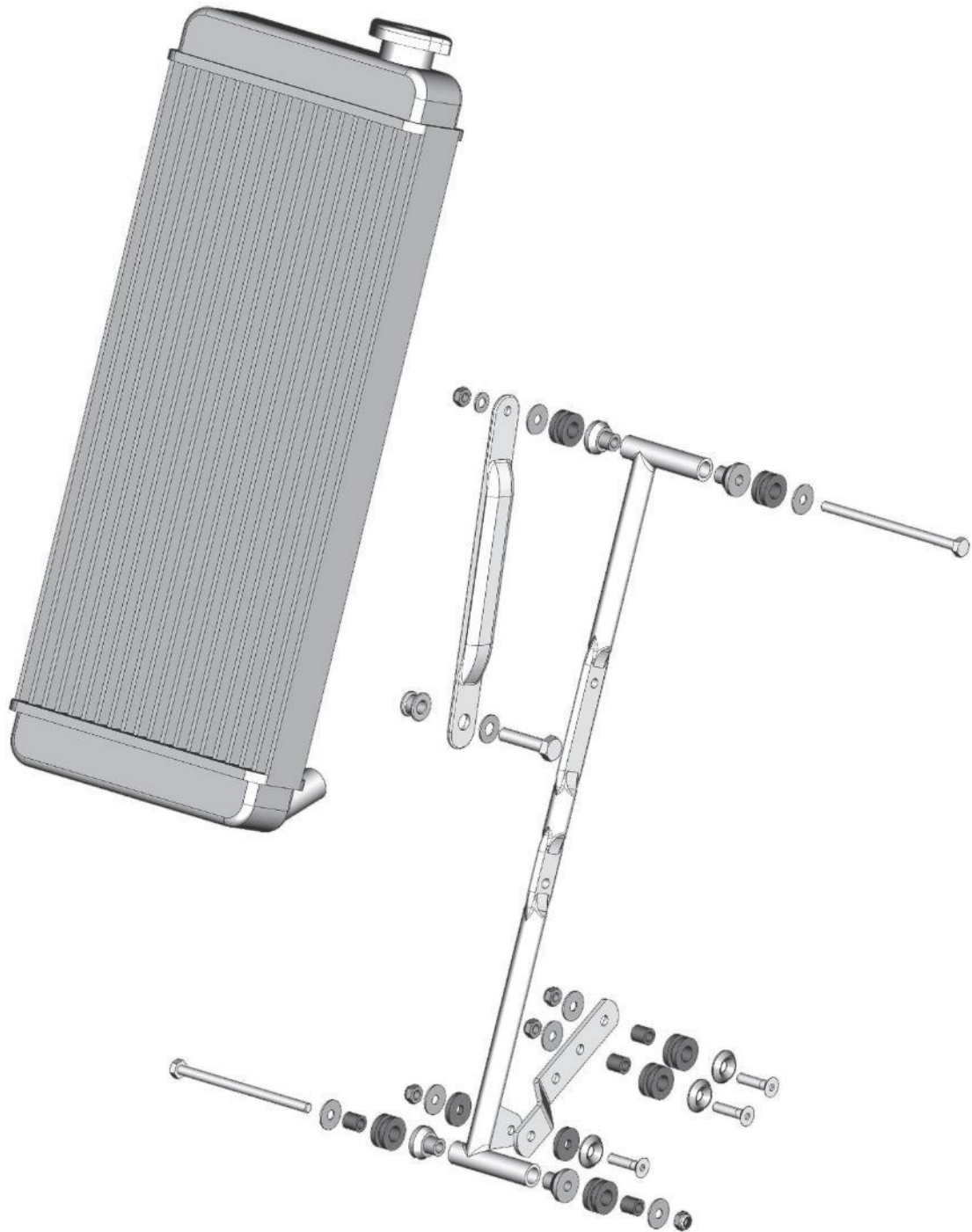



... Section D.9

*RADIATOR DIMENSION*

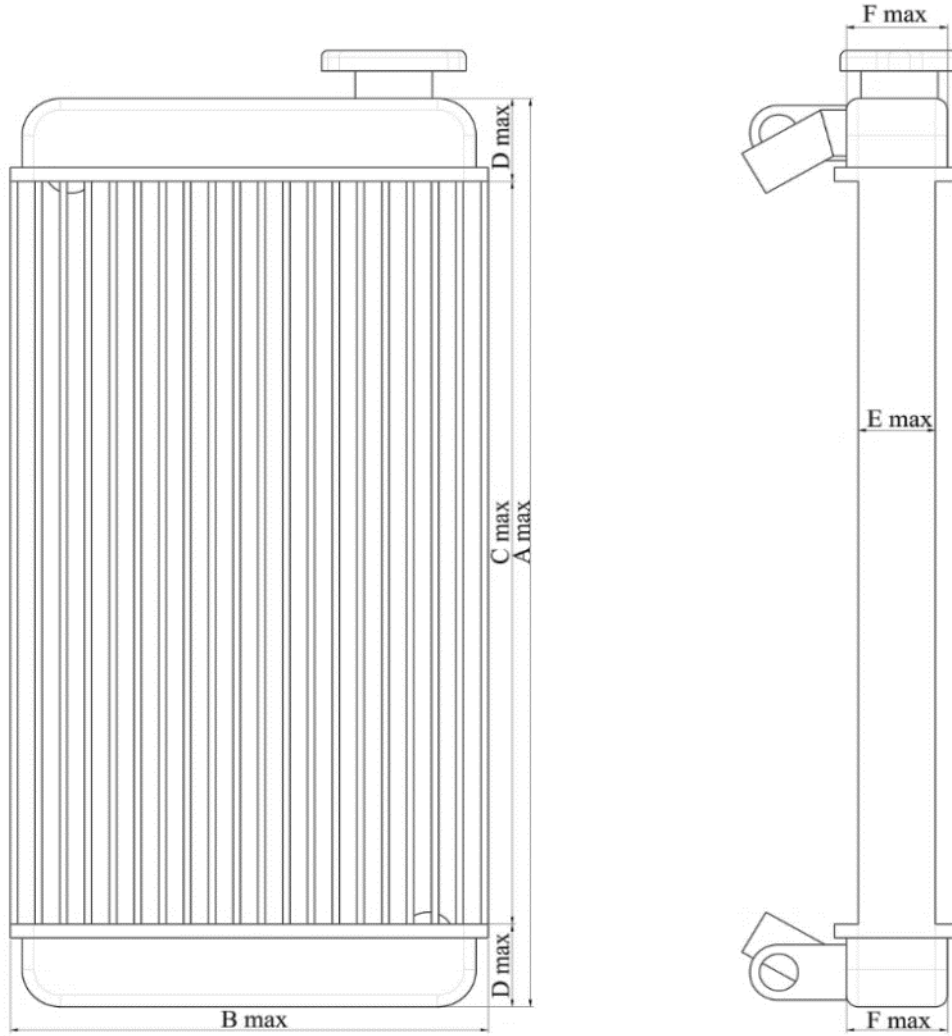

	<b>A</b>	<b>B</b>	<b>C</b>	<b>D</b>	<b>E</b>	<b>F</b>
<b>ROK GP</b>	480	210	395	45	32	45

... Section D.9

COOLING SYSTEM

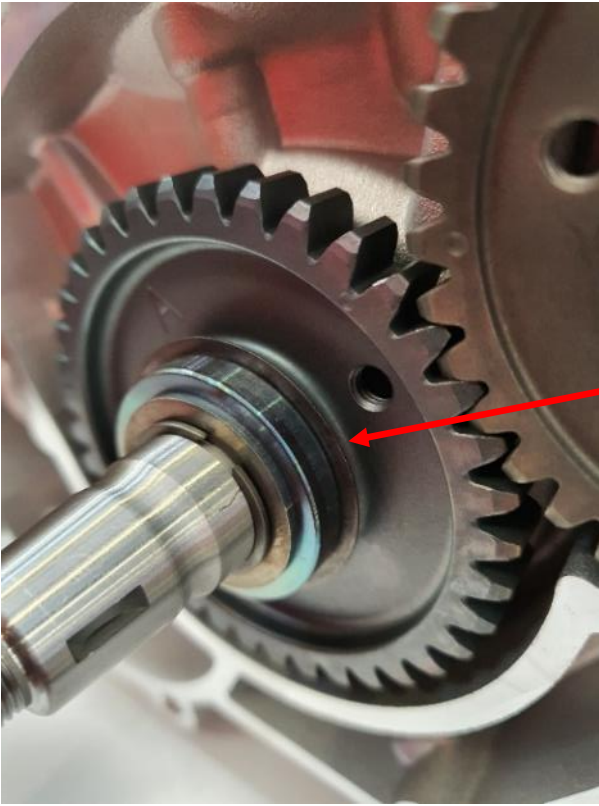

*It is allowed to use only the external water pump with the change indicated in the picture [HERE](#).*

WATER PUMP DRAWING

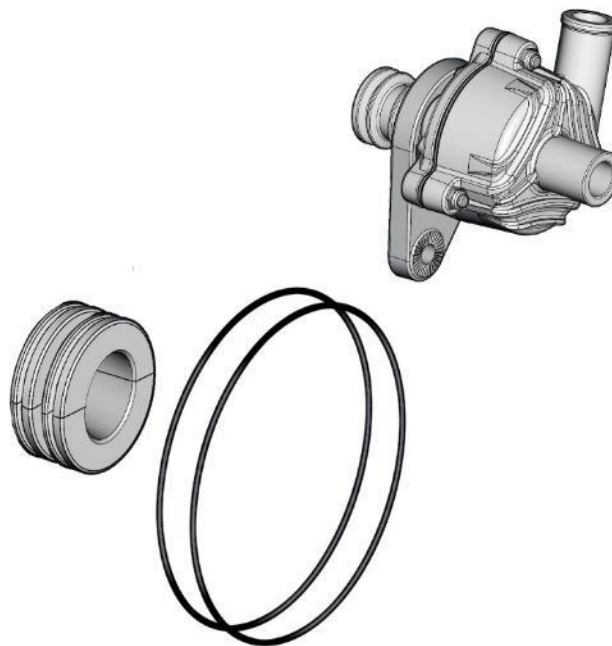

**D.10 PICTURES AND MARKING**

*PISTON – 2 Options*

*Mandatory to have the brand VORTEX cast piston as shown in the picture.  
Mandatory to have the number of the mold cast as shown in the picture.*



*REED PETAL*

*FIBER GLASS REED PETALS MUST BE BOTH MANDATORY, ORIGINAL AND BRANDED OTK AS SHOWN IN THE PICTURES.*

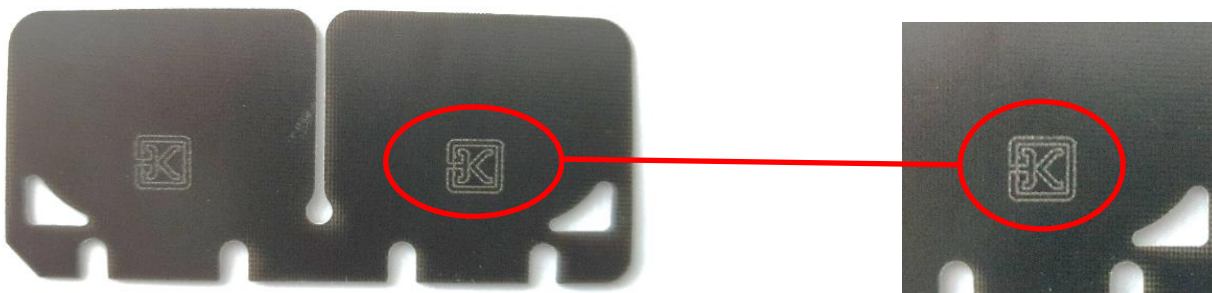

... Section D.10

EXHAUST

DURING EXAMINATION, ON THE EXHAUST IT MUST BE INDICATED THE IDENTIFICATION LOGO ROK GP, IMPRINTED DIRECTLY BY THE MANUFACTURER.



CONROD MARKING

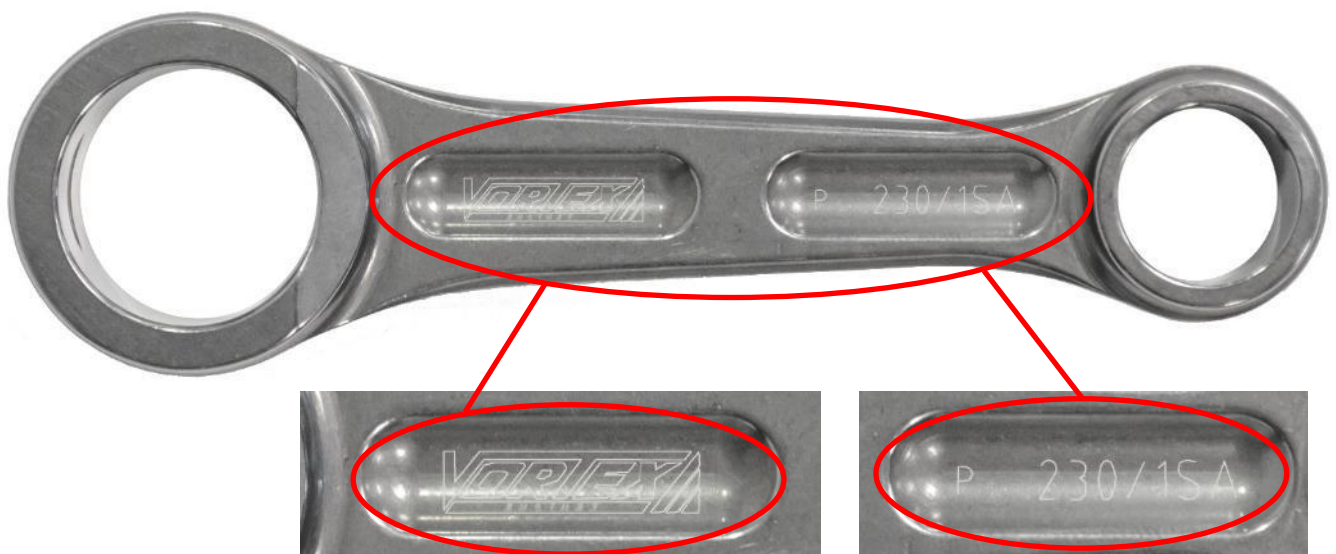

... Section D.10

THE REED VALVE INLET MARKING

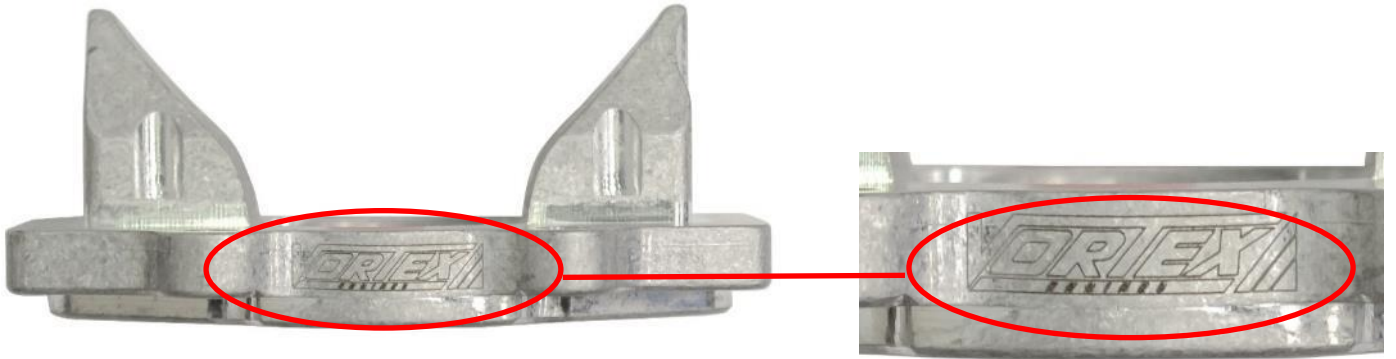





**122H**

## **Appendix A to the Vortex Rok – GP TaG 125 Engine Homologation**

**OEM means: Original Engine Manufacturer (Vortex) or an organisation that makes component parts used by and supplied by Vortex for exclusive use in the Rok-GP Engine.**

The following notes are additional to the details contained in these homologation documents for the **Vortex Rok - GP 125 TaG Engine** (the “Engine”) and are to be read in conjunction with the specifications and details contained therein; they form part of the Homologation Documents for the Engine.

The Engine must at all times be used and presented in strict conformity with the specifications detailed in the homologation documents. All engines must be imported into Australia by Kingarth Pty Ltd (Patrizicorse). Engine numbers will be recorded. **Unless otherwise expressly permitted by Karting Australia, the Engine must use only Vortex OEM parts in accordance with this Homologation Document.**

Neither the Engine nor any of its ancillary components may be modified other than in accordance with the Karting Australia Rules and these homologation documents. Any removal, addition or polishing of material is strictly forbidden. Sandblasting, glass bead blasting, vapor blasting, wet blasting, liquid honing, peening, acid etching, spark eroding and/or any other method of metal removal or displacement is strictly forbidden.

The use of thermal barrier coatings/ceramic coatings on or in the Engine/Engine components and on or in exhaust components is prohibited.

The use of anti-friction coatings on or in the Engine/Engine components other than OEM pistons is prohibited.

**UNLESS IN THE KARTING AUSTRALIA RULES AND/OR THESE HOMOLOGATION DOCUMENTS, IT SAYS THAT YOU CAN DO SOMETHING TO THE ENGINE OR ANY OF ITS COMPONENTS, THEN YOU CANNOT.**

### **1. Cylinder**

- a. All ports must be of intended design as manufactured and conforming to the homologation drawings.
- b. No modifications or grinding to the ports is allowed.
- c. Water connections to the cylinder are free but must retain the homologated position and threaded sizes.

### **2. Base Gaskets**

- a. The type of material is a non-tech item.
- b. The base gasket/gaskets must be a minimum of 0.20mm and a maximum of 0.50mm.
- c. More than 1 base gasket can be used.

### **3. Cylinder Head**

- a. Cylinder Head must be OEM and conform to the homologation drawings.
- b. The combustion chamber volume shall be a minimum of 9.5cc (including insert volume).
- c. Water connections to the cylinder head are free but must retain the homologated position and threaded sizes.
- d. Cylinder head profile must not vary from the original profile and will be checked with the VORTEX Cylinder Head Profile Gauge (part number WA063/SROK).

### **4. Squish Gap**

- a. The Cylinder Head Squish clearance shall be a minimum of 1 mm as per homologation.
- b. Squish shall be measured using digital verniers and 2mm solder wire (tin).

- c. When inserted in the cylinder the Engine shall be rotated until the solder is squeezed between the head and piston crown.
- d. The thickness of the flat section closest to the step formed by the piston ring must be measured using the thin tip of the caliper jaws.
- e. This process shall be conducted on both the right and left-hand side of the engine parallel to the piston pin.
- f. The two measurements shall be averaged out and must equal no less than 1 mm.

**5. Crankcase, Crankshaft and Con Rod**

- a. Must be OEM and conform to homologation drawings.

**6. Piston**

- a. Piston must be OEM, supplied by VORTEX with "VORTEX" marking internally, Piston size on dome and conform to homologation drawings.
- b. No modifications are permitted.

**7. Piston Pin**

- a. No special alloys are allowed, must be of magnetic material and comply with the drawing as supplied by the manufacturer.

**8. Clutch**

- a. Must be OEM, conform to the homologation drawings and display the original VORTEX markings and W1751/1KFC on the clutch hub. No modifications are permitted.
- b. ONLY Original Clutch Drum part no. W1773/ROK may be used and is interchangeable with the clutch hubs listed above and must display original "VORTEX" markings on the outside.

**9. Reed Block, Reed Valves and Inlet Conveyor**

- a. The only reed petals to be used are the genuine VORTEX Fiberglass reed petals with VORTEX markings.
- b. Minimum thickness of the Reed Petals must be 0.3mm.
- c. Reed block must be OEM as supplied by VORTEX.

**10. Carburetor**

- a. Dell'Orto VSH 30.
- b. The only allowed changes to the Dell'Orto VSH 30 carburetor are main jet, needle clip position and needle valve (allowed options). No other change or modification is allowed.
- c. The carburetor airbox clamps must be used as supplied.
- d. Only OEM Dell'Orto parts are allowed and must be of the same type and size as originally supplied. Part numbers as per Homologation document page 44.
- e. All jets must be original Dell'Orto jets.
- f. Stamped numbers on parts DO NOT guarantee the accuracy of the part.
- g. Standard Dell'Orto VSH 30 Set Up:
  - i. Slide: #40
  - ii. Needle: K33
  - iii. Outer pilot: #60
  - iv. Inner pilot: CD1 ONLY
  - v. Emulsion tube: DP268 ONLY
  - vi. Floats: 4gm as supplied standard
  - vii. Maximum venturi size: 30mm
  - viii. Needle Valve 250 or Needle Valve 270

### **11. Induction Silencer**

- a. No external form of air ducts forcing air inside of air box is permitted.
- b. Air box clamps must be properly tightened to secure the air box.
  - i. The air box must be properly secured at all times.

### **12. Ignition**

- a. The woodruff ignition rotor key must be retained and may not be modified.
- b. The spark plug cap must incorporate a minimum of a 5k $\Omega$  resistor.
- c. In the event of required repairs the plastic fittings registered and homologated as parts of the electrical systems are permitted to be replaced with non-supplied fittings.
- d. Standard (3 mm) +/-1 mm.

### **13. Exhaust**

- a. The OEM exhaust must be used as supplied.
  - i. No treatment of any kind is allowed.
  - ii. No form of thermo wrapping is allowed.
  - iii. No modification to the silencer end cap is allowed.
  - iv. It must not leak exhaust gases – all engine exhaust gases must pass through the exhaust header pipe, the muffler and the silencer, exiting the system at the silencer end cap.
- b. The internal dimensions may not be altered for any reason – including but not limited to because of rust.
- c. Exhaust temperature sensor:
  - i. Only one EGT exhaust temperature sensor is allowed.
  - ii. One hole only can be drilled on the exhaust pipe for sensor.
  - iii. No specific location is required for the exhaust temperature sensor.
  - iv. Any hole not being used must be completely plugged if exhaust sensor is not being used.

### **14. Exhaust Manifold**

- a. As per Homologation File.
- b. ROK GP Restrictor is in accordance Homologation document.
  - i. Note: if in the opinion of Karting Australia, the use of an alternate Restrictor for TaG 125 and/or TaG 125 Restricted Competition, is necessary solely for the purpose of performance parity, details of the Restrictor/s required to be used will be added to this Homologation and/or included in the Class Rules.
- c. The exhaust header must not be cracked or leak exhaust gas.
- d. When a restrictor is fitted, all exhaust gases must pass through the internal hole of the restrictor.
- e. The mating surfaces between the cylinder/manifold and manifold/muffler must be sealed to prevent any leakage of exhaust gas. It is recommended that High Temperature RTV Silicone is applied between the surfaces to ensure that a gastight seal is created and maintained at all times.
- f. A go-no go gauge will be used to control restrictor headers. It is allowed to clean the restrictor header with scotch brite and solvents.

### **15. Cooling System**

- a. OTK Radiator 0093.TA1 Must be OEM as Supplied.
  - i. Minor welding is allowed to cover up small holes.
  - ii. Additional metal mounting brackets may be used to secure Radiator.

- iii. All radiators **MUST** be mounted on the left side of the driver and placed above the chassis frame. Supplementary radiators, if needed, may be mounted either on the left or right side.
- iv. The use of racing tape or similar as an air flow restriction device is permitted. Tape may be removed at any time but must remain with the kart and cannot be discarded on the circuit
- v. It is permissible to fit a sealed recovery tank with a minimum capacity of 25ml to make the water-cooling system a sealed unit.
- b. Water hoses:
  - i. Water hoses are not required to be OEM. It is not mandatory to use a thermostat but if used, it must be OTK W866.
  - ii. If a thermostat is not used, the only join permitted in the hose is for a water temperature sensor.
  - iii. Any hot head water heating system will be allowed to be used.

#### **16. Water Pump**

- a. Only one (1) water pump may be fitted in accordance with Appendix A.
- b. The external water pump must be located on the traverse tube of the chassis under the seat.
- c. The water pump must be wholly belt-driven by the axle. For the sake of clarity, it must not be electrically powered in any way.
- d. Non-Glycol additives are allowed for lubrication

#### **17. Fuel System**

- a. All fuel system components must be utilised as supplied.
- b. No additional components are permitted.
- c. Any fuel filter, must be placed between the fuel tank and the original fuel pump.
- d. Vent tubes are mandatory, fittings must remain in the carburetor.
- e. The fuel pump must be mounted to the engine.

#### **18. Wiring Harness**

- a. Repair of the wiring loom is permitted. Must use OEM components as supplied.
- b. The plastic fittings homologated as components of the electrical loom for the ignition and starter assembly are allowed to be replaced with non-genuine fittings.
- c. If any wire is damaged or cut, a wire coupling can be used to repair cut wire area only.
- d. Replacing the ends of the harness is acceptable with similar part.
- e. Additional grounds are allowed.
- f. No additional components are permitted.

#### **19. Spark Plugs**

- a. Only the following spark plugs are allowed:
  - i. NGK B/BR EG (heat range open) and BRISK L10SL AND L11SL are allowed.
  - ii. Must be original and no modification is allowed. (Changing the spark plug gap is allowed).
- b. Spark plug washer must be as supplied unless a head temperature gauge sensor is in place.
- c. Spark Plug Cap must be as supplied.

#### **20. Power Valve**

- a. Only new style short power valve caps are legal. Part # W10172/GP.
- b. Power Valve springs must be OEM and as supplied.





## Gauges and Compliance Testing Tools and Testing Procedures

### Head Dome Profile Template (refer to page 14 of the Homologation document)

Use Head Dome Profile Template Tool:



Procedure:

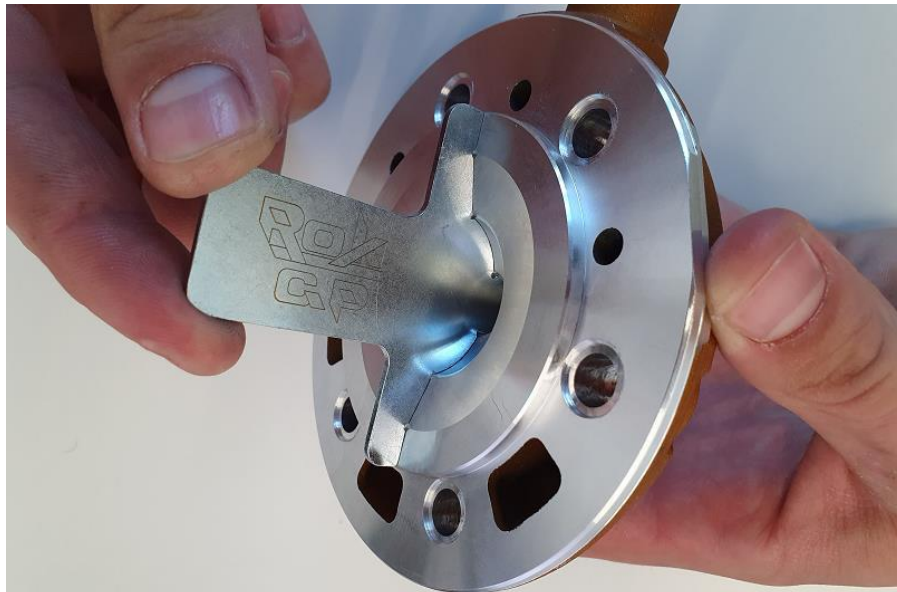

#### Steps

1. Remove the engine head.
2. Gently wipe clean the cylinder head from deposits (carbon deposits and dirt) (Exercise care, avoiding scratching it.)
3. Insert the OEM head dome profile template. Rotate the Template 360°.
4. **Check that the template profile matches the head dome's profile.**

#### Remarks

1. Slight, very little and uniform clearance allowed (refer to the picture above).

## Exhaust Valve Control Gauge (refer to page 15 of the Homologation document)

Use the:

Control Gauge Base Plate Number: 0428730040



Control Gauge Rod Number: 8007

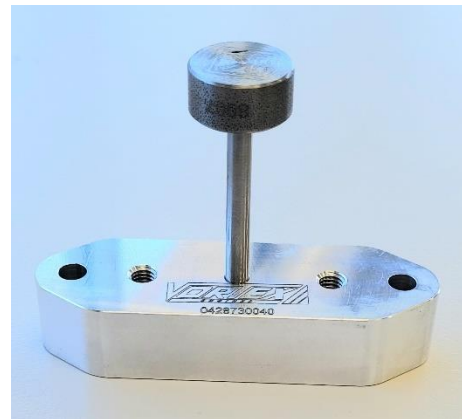
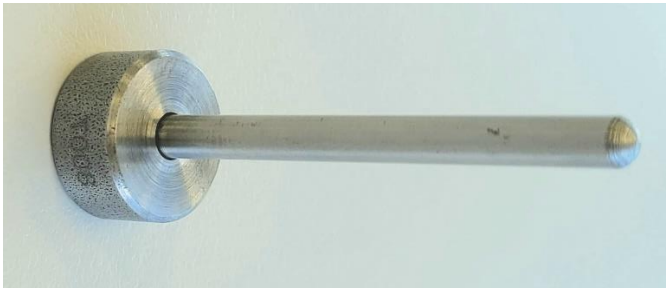

## Procedure

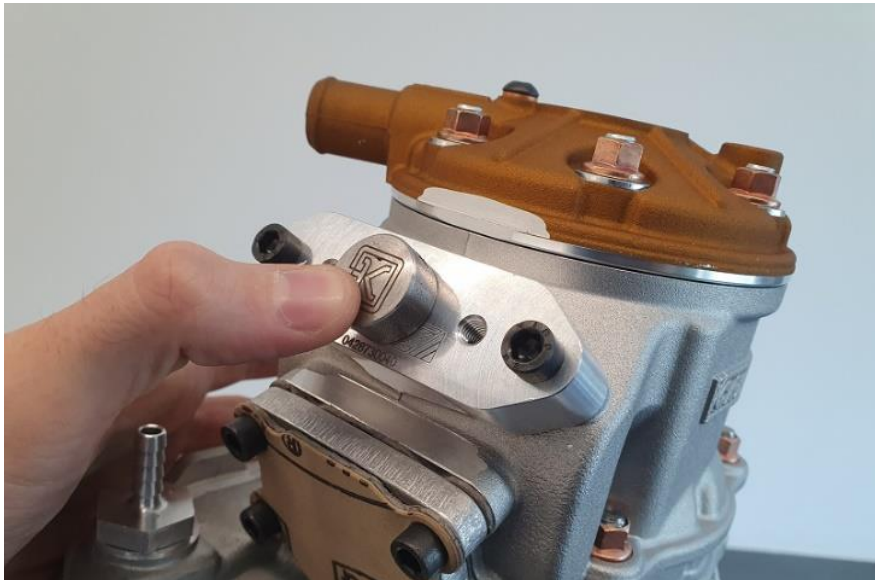

## Steps

1. Remove the complete power valve assembly.
2. Remove the power valve gasket.
3. Secure the OEM control gauge base plate No. 0428730040 as shown.
4. Insert the OEM control gauge rod No. 8007 as shown.
5. **Check that there is no gap between gauge rod's flange and gauge base plate.**

### Exhaust Main Port Control Gauge (refer to page 15 of the Homologation document):

Use the:

Control Gauge Base Plate Number: 0428730020



Control Gauge Rod Number: 8003

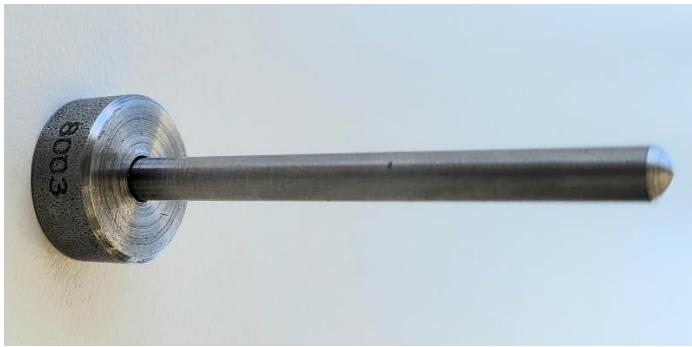

### Procedure

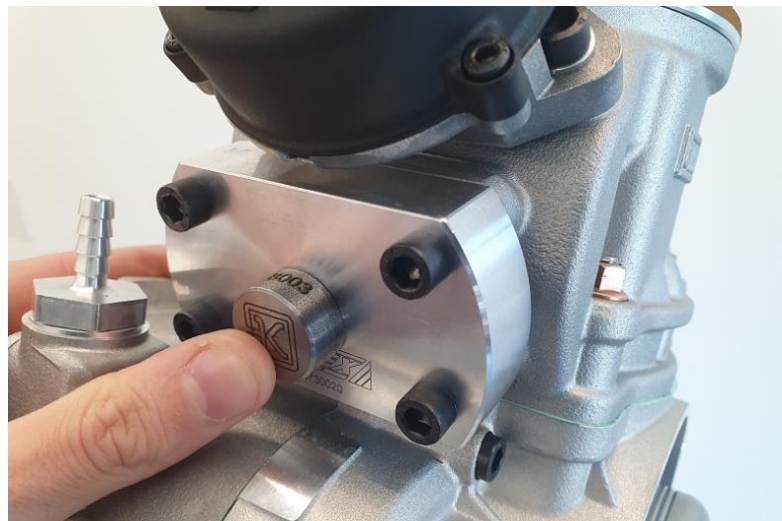

### Steps

1. Remove the exhaust manifold.
2. Remove spacer and gaskets.
3. Secure the Control Gauge Base Plate No. 0428730020.
4. Insert the Control Gauge Rod No. 8003.
5. **Check that there is no gap between gauge rod's flange and gauge base plate.**

**Restricted Exhaust Manifold Control Gauge (refer to page 17 of the Homologation document)**

Use the:

Control Gauge Number: V.25



**Procedure**



**Steps**

1. Insert the Control Gauge No. V.25
2. Rotate the Gauge 360°.
3. Check that the no-go gauge does not enter into the narrow section of the Restrictor.