

NATIONAL HOMOLOGATION FORM

Homologation N°

114H/RH



Manufacturer	BRP-POWERTRAIN GMBH & CO KG
Make	ROTAX
Model	125 MAX DD2 EVO
Validity of the homologation	6 years
Number of pages	27 Plus Appendix A

This Homologation Form reproduces descriptions, illustrations and dimensions of the engine at the time that Karting Australia conducted the homologation.



PHOTO OF DRIVE SIDE OF ENGINE



PHOTO OF OPPOSITE SIDE OF ENGINE

Signature and stamp of Karting Australia

National Technical Commissioner
20 March 2023



PHOTO OF DRIVE SIDE OF THE COMPLETE ENGINE

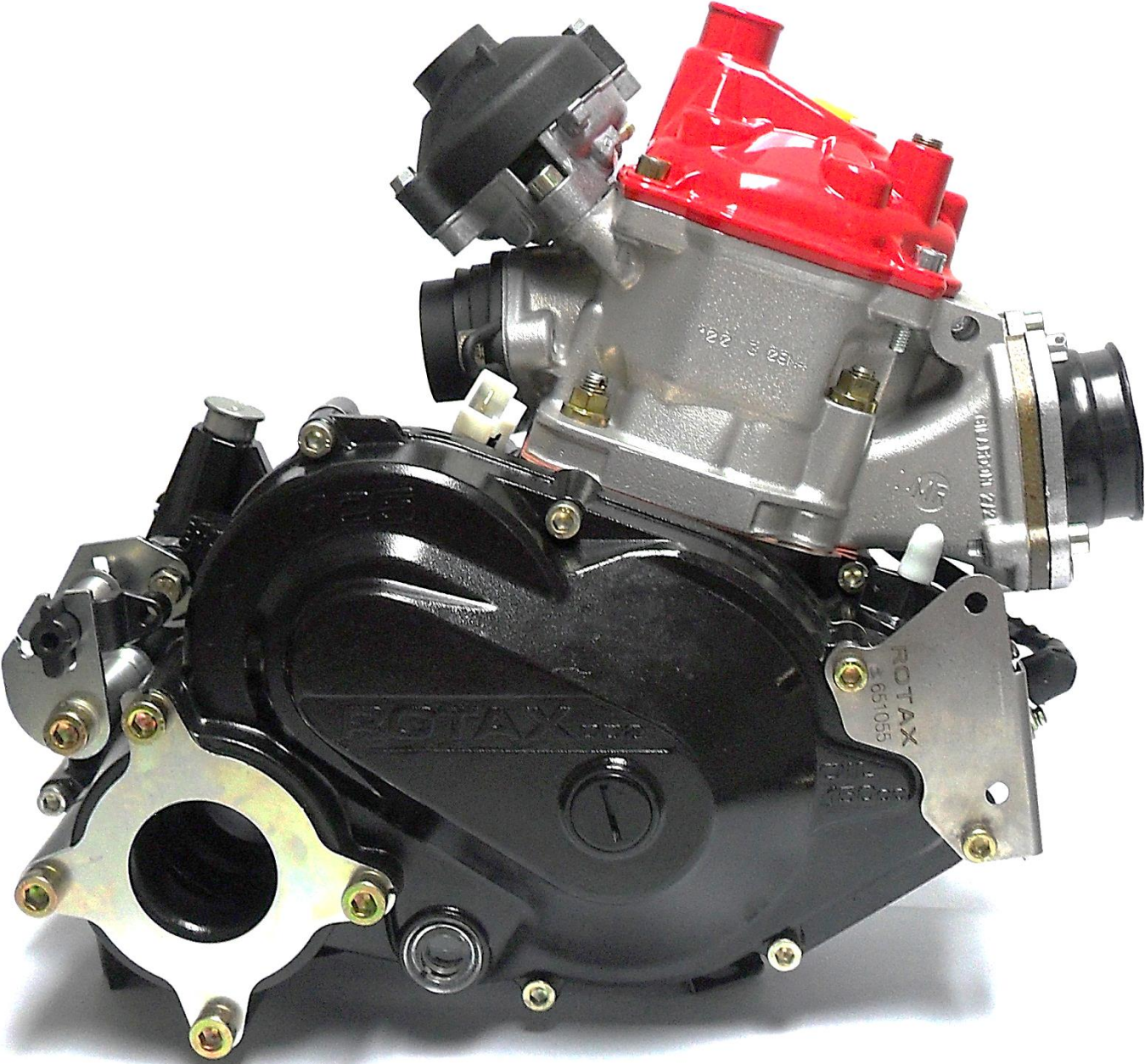

PHOTO OF OPPOSITE DRIVE SIDE OF THE COMPLETE ENGINE

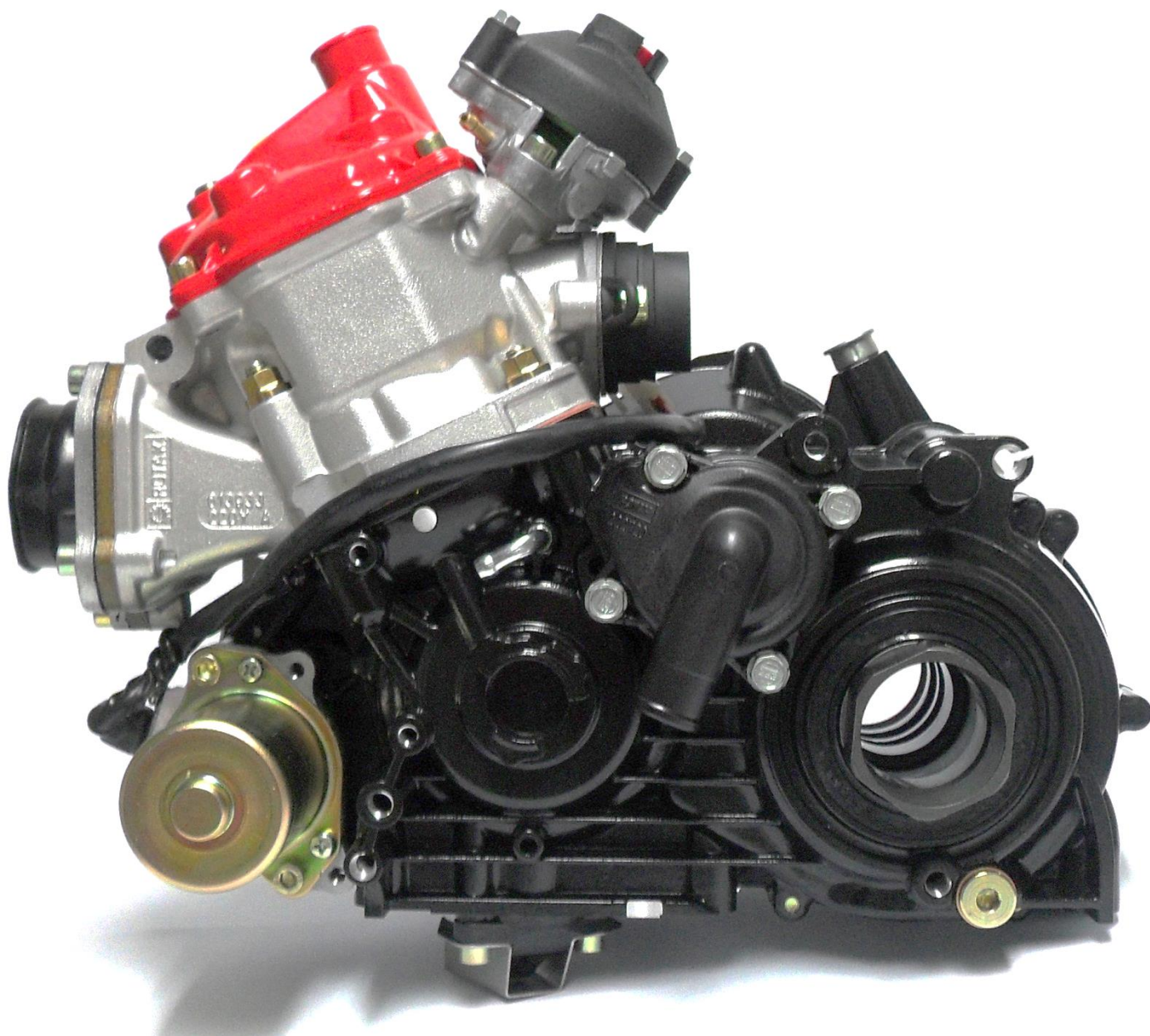

PHOTO OF THE REAR OF THE COMPLETE ENGINE

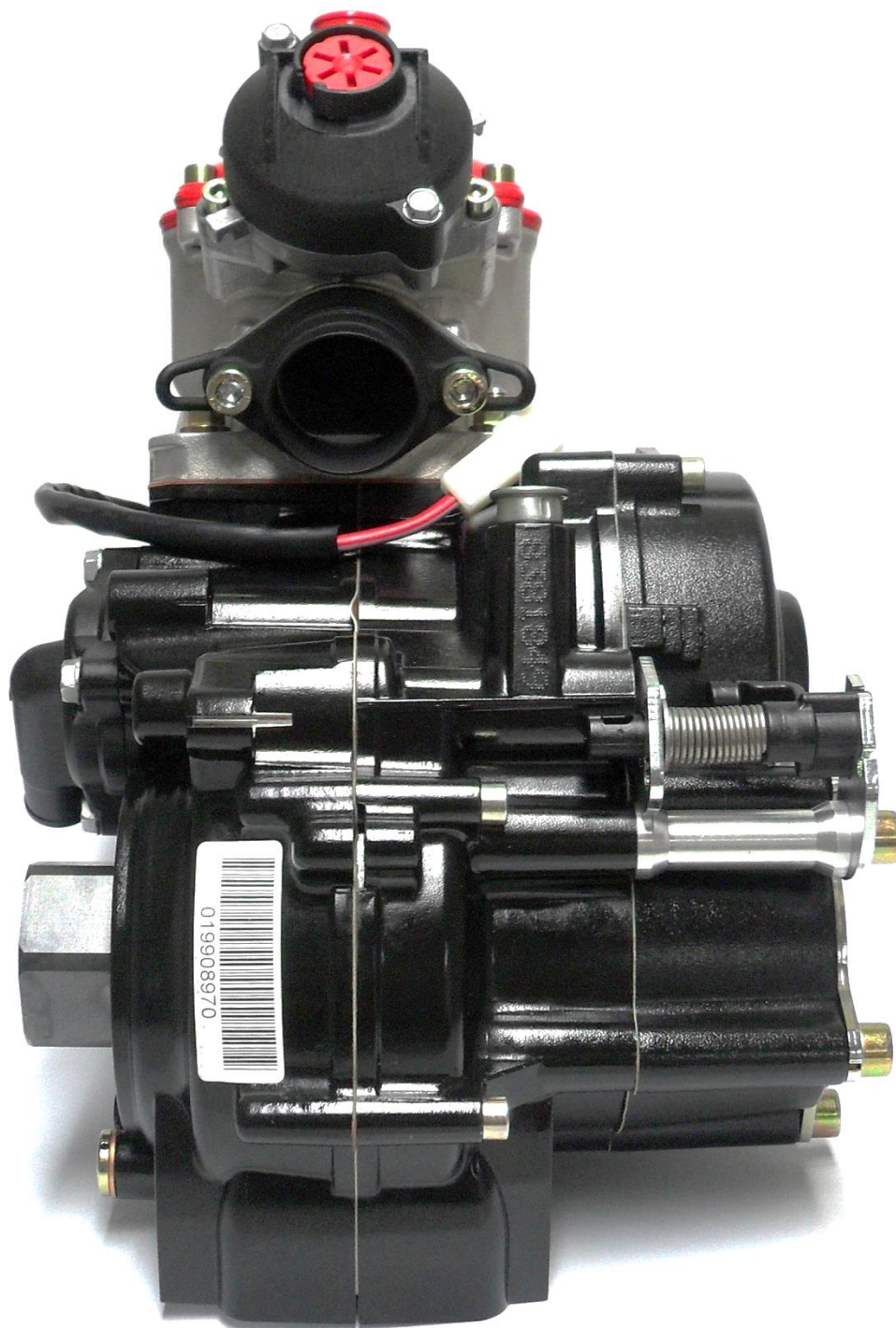

PHOTO OF THE FRONT OF THE COMPLETE ENGINE

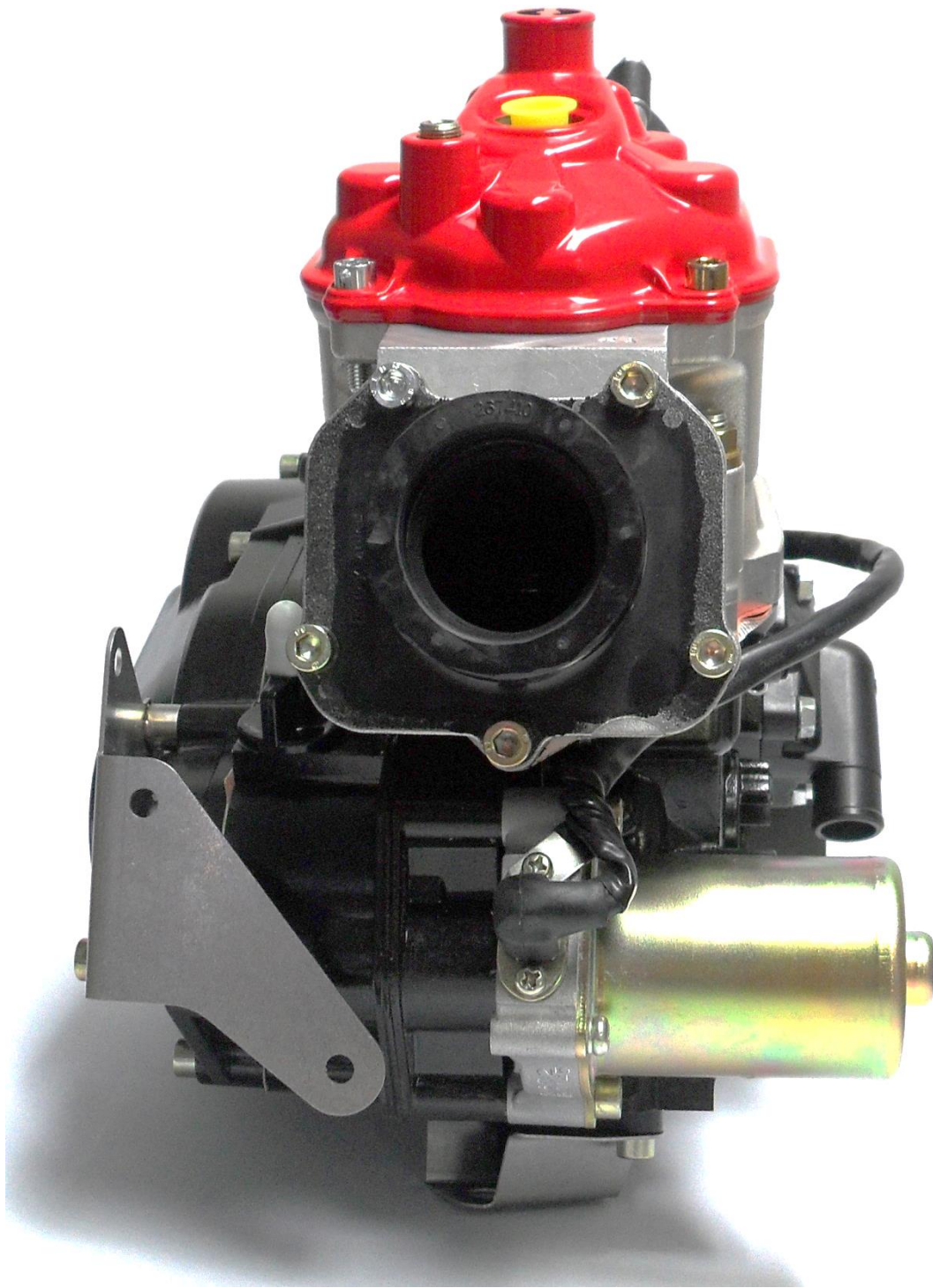

PHOTO OF THE COMPLETE ENGINE TAKEN FROM ABOVE

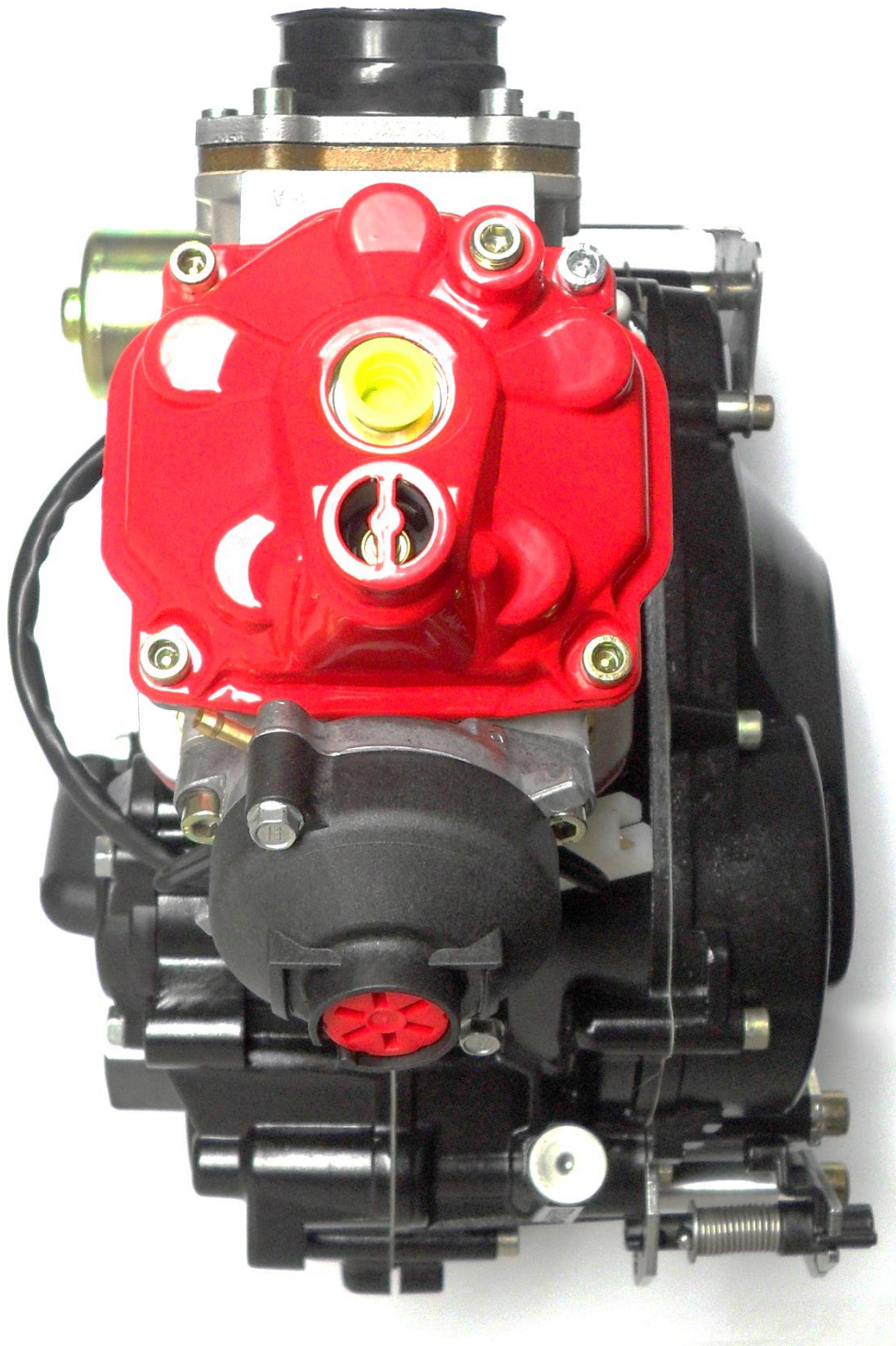
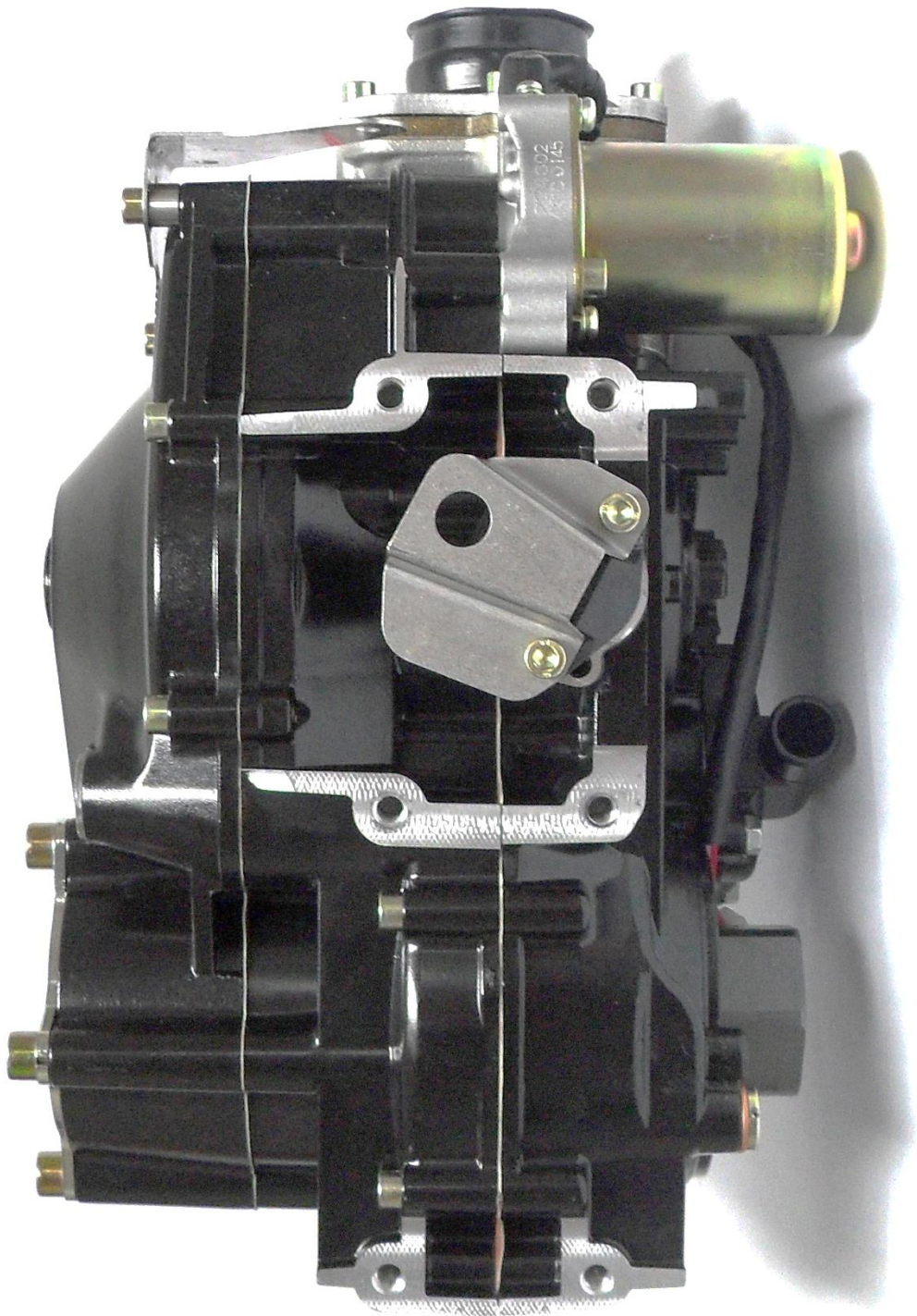

PHOTO OF THE COMPLETE ENGINE TAKEN FROM BELOW



TECHNICAL INFORMATION

A	CHARACTERISTICS	
<i>The number of decimal places must be 2 or comply with the relevant tolerance.</i>		<i>Tolerances & remarks</i>
Cylinder		
<i>Volume of cylinder</i>	<u>125cm³</u>	<u><125cm³</u>
<i>Original bore</i>	<u>54mm</u>	--
<i>Theoretical maximum bore</i>	<u>54.08mm</u>	--
<i>Original Stroke</i>	<u>54.5mm</u>	--
<i>Number of transfer ducts, cylinder/sump</i>	<u>5 / 3</u>	--
<i>Number of exhaust ports / ducts</i>	<u>1</u>	--
<i>Volume of the combustion chamber</i>	<u>8.9cm³</u>	minimum
<i>Volume of the combustion chamber in the cylinder head</i>	<u>11.6cm³</u>	minimum
Crankshaft		
<i>Number of bearings</i>	<u>2</u>	--
<i>Diameter of bearings</i>	<u>30MM</u>	±0.1mm
<i>Minimum weight of crankshaft</i>	<u>2200 g</u>	minimum
<i>All parts represented on page 17 photo</i>		
Balance shaft		
<i>Minimum weight of balance shaft</i>	<u>255g</u>	minimum
<i>Percentage of balancing</i>	<u>TBA %</u>	minimum
Connecting rod		
<i>Connecting rod centreline</i>	<u>100mm</u>	±0.2mm
<i>Diameter of big end</i>	<u>26mm</u>	±0.05mm
<i>Diameter of small end</i>	<u>19mm</u>	±0.05mm
<i>Min. weight of the connecting rod</i>	<u>100g</u>	minimum
Piston		
<i>Number of piston rings</i>	<u>1</u>	
<i>Min. weight of the bare piston</i>	<u>125g</u>	minimum
Gudgeon pin		
<i>Diameter</i>	<u>15mm</u>	±0.05mm
<i>Length</i>	<u>45.6mm</u>	±0.15mm
<i>Minimum weight</i>	<u>32.1g</u>	Minimum
Clutch		
<i>Minimum weight</i>	<u>1000g</u>	minimum
<i>Of all the parts represented on the page 21 technical drawing</i>		



B	<i>OPENING ANGLES</i>	
<i>Of the inlet (main transfer ports)</i>	<u>127°</u>	±2°
<i>Of the inlet (secondary transfer ports, for 5 transfer ducts engine)</i>	<u>126°</u>	±2°
<i>Of the exhaust</i>	<u>198°</u>	±2°
<i>Of the boosters</i>	<u>130°</u>	±2°

* Angular reading by inserting a 0.2 x 5mm gauge.

C	<i>MATERIAL</i>
<i>Cylinder head</i>	<u>ALUMINIUM</u>
<i>Cylinder</i>	<u>ALUMINIUM</u>
<i>Cylinder wall</i>	<u>GILNISIL COATED</u>
<i>Sump</i>	<u>ALUMINIUM</u>
<i>Crankshaft</i>	<u>STEEL</u>
<i>Connecting rod</i>	<u>STEEL-ALLOY</u>
<i>Piston</i>	<u>ALUMINIUM</u>



D.1 CYLINDER UNIT

EXPLODED DRAWING OF THE CYLINDER, CYLINDER HEAD AND EXHAUST MANIFOLD UNIT

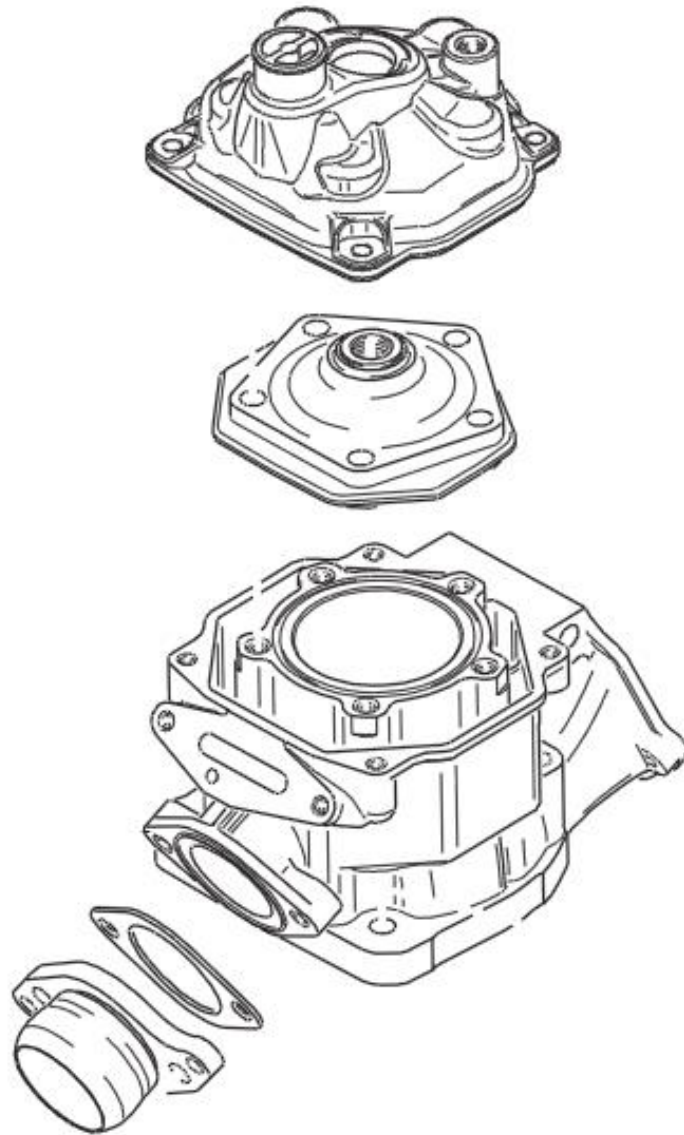

Without screws or gaskets.

The aim of the exploded drawings is to identify the principles, the functioning and the whole mechanical unit

DRAWING OF THE CYLINDER DEVELOPMENT

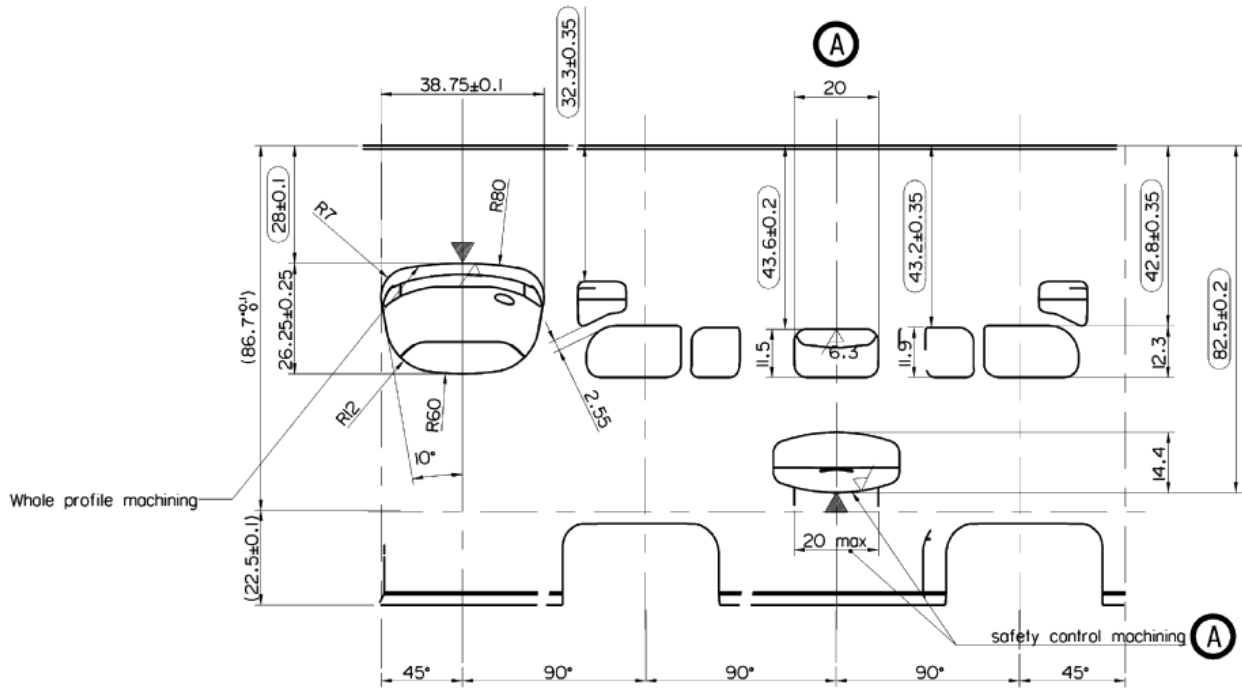

Indicate on the drawing :

- B1/B2 = minimum thickness of the inlet (transfers) ribs.
- A1/A2/A... = maximum inlet width measured at the chord.
- E1/E2 = minimum thickness of the exhaust rib (if existing).
- C1/C2/C... = maximum exhaust width measured at the chord.

DRAWING OF THE CYLINDER BASE without dimensions

PHOTO OF THE CYLINDER BASE

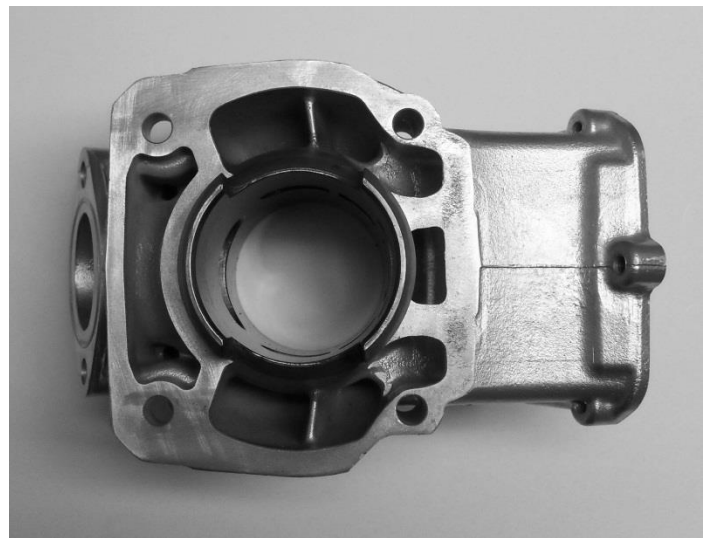
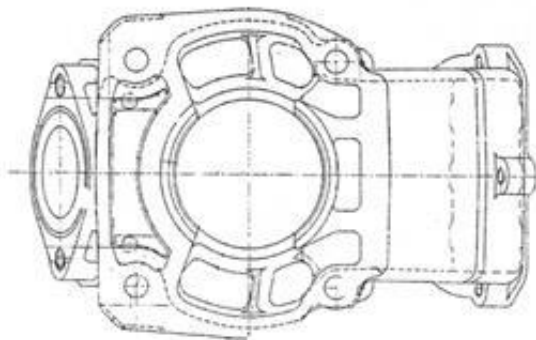

... Section D.1

DRAWING OF THE CYLINDER HEAD AND OF THE COMBUSTION CHAMBER without dimensions

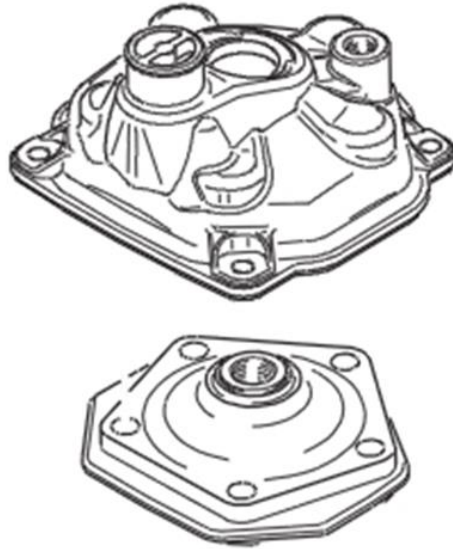

PHOTO OF THE CYLINDER HEAD

PHOTO OF THE COMBUSTION CHAMBER IN THE CYLINDER HEAD



VERTICAL CROSS SECTION VIEW OF CYLINDER WITH LINER, without dimensions

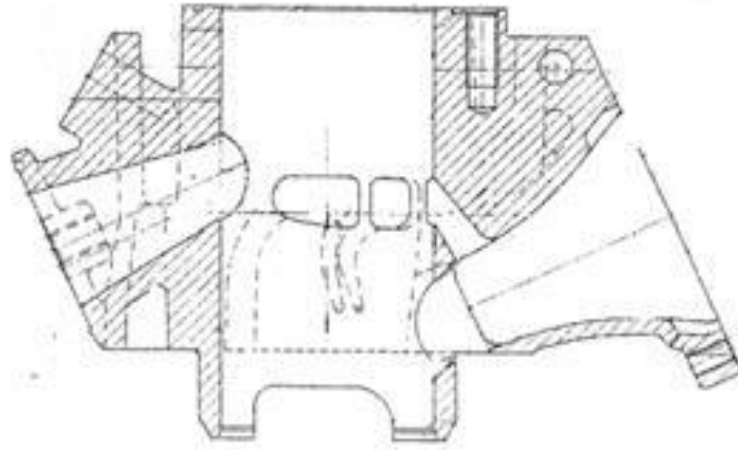
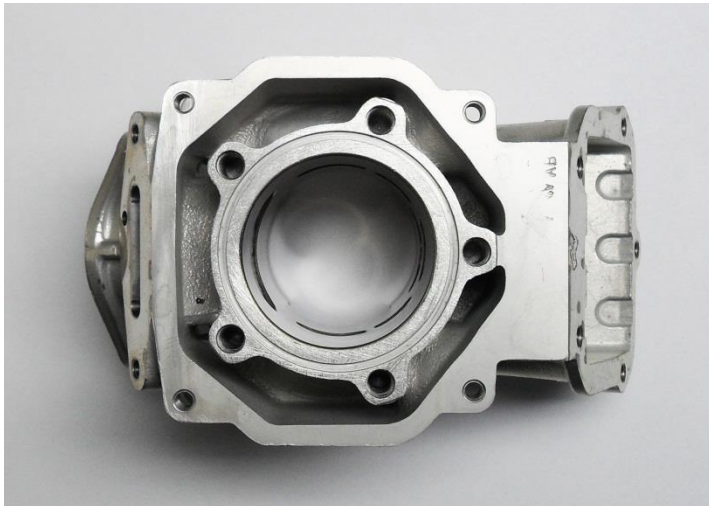
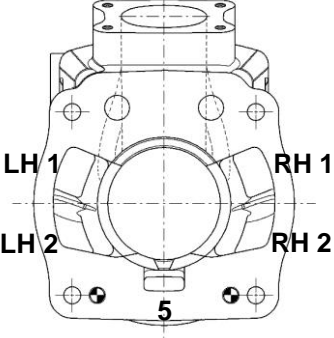
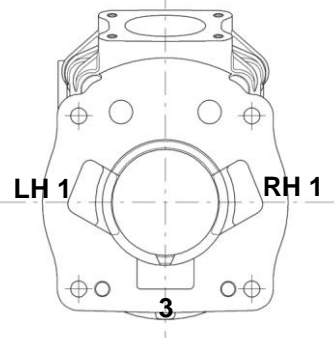

PHOTO OF THE CYLINDER FROM ABOVE

PHOTO OF THE CYLINDER FROM RH SIDE



... Section D.1

<i>TRANSFER DUCTS VOLUME</i>			
<i>Transfer position on 5-transfer cylinder</i>	<i>Transfer position on 3-transfer cylinder</i>	<i>TRANSFER No.</i>	<i>VOLUME in cm³</i>
		<i>Transfer No. 1 LH</i>	--.. +/- 5 %
		<i>Transfer No. 2 LH</i>	--.. +/- 5 %
		<i>Transfer No. 3 or 5</i>	--.. +/- 8 %
		<i>Transfer No. 2 RH</i>	--.. +/- 5 %
		<i>Transfer No. 1 RH</i>	--.. +/- 5 %

<i>EXHAUST DUCT LENGTH</i>		
	ANGLE α in °	Minimum in mm
	--° +/-1°	-- mm
<i>The L min. dimension will be the result of the value taken on the reference engine minus 5 mm.</i>		

... Section D.1

INTERNAL PROFILE OF THE EXHAUST DUCT

Templates of the internal dimensions of the exhaust duct: gasket plane of the manifold.

FRONT VIEW DRAWING – with dimensions

Minimum template

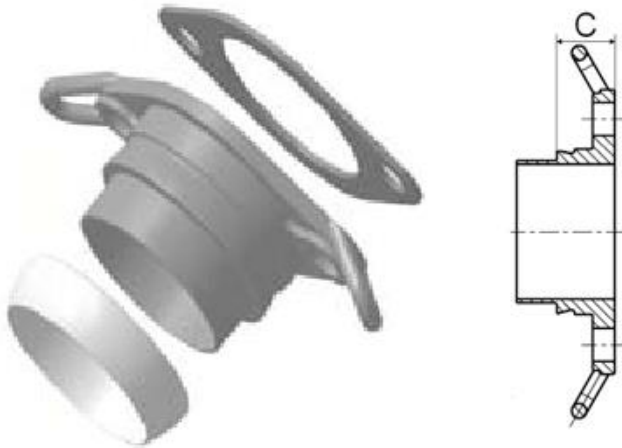

Measurement 'C' must be minimum 15.5mm

Maximum template

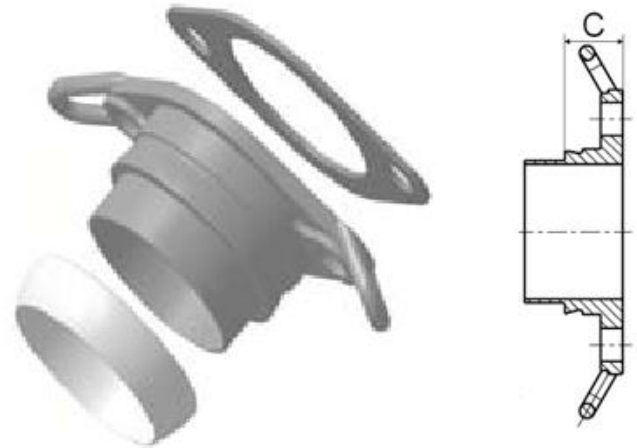

Measurement 'C' must be maximum 16.5mm

- *Maximum template: internal profile of the gasket plane of the manifold of the original cylinder plus 1 mm*
- *Minimum template: internal profile of the gasket plane of the manifold of the original cylinder minus 1 mm*
- *Thickness: 5 +/- 0,05 mm*

EXHAUST SYSTEM

The silencer must be mounted in a Position where the direction of the 90° elbow outlet (direction of the hot exhaust gasses) does not harm any component of the chassis.

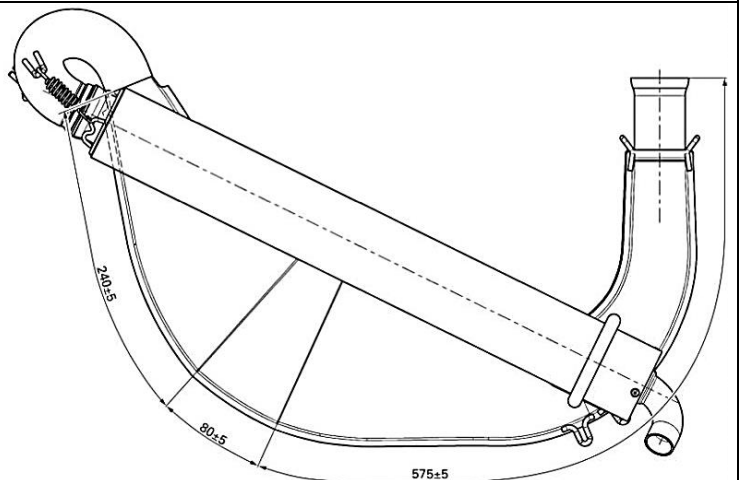

D.2 CONROD, CRANKCASE, CRANKSHAFT & PISTON

EXPLODED DRAWING OF THE PISTON, CRANKSHAFT, CONNECTING ROD AND CRANKCASES UNIT (exploded crankshaft)

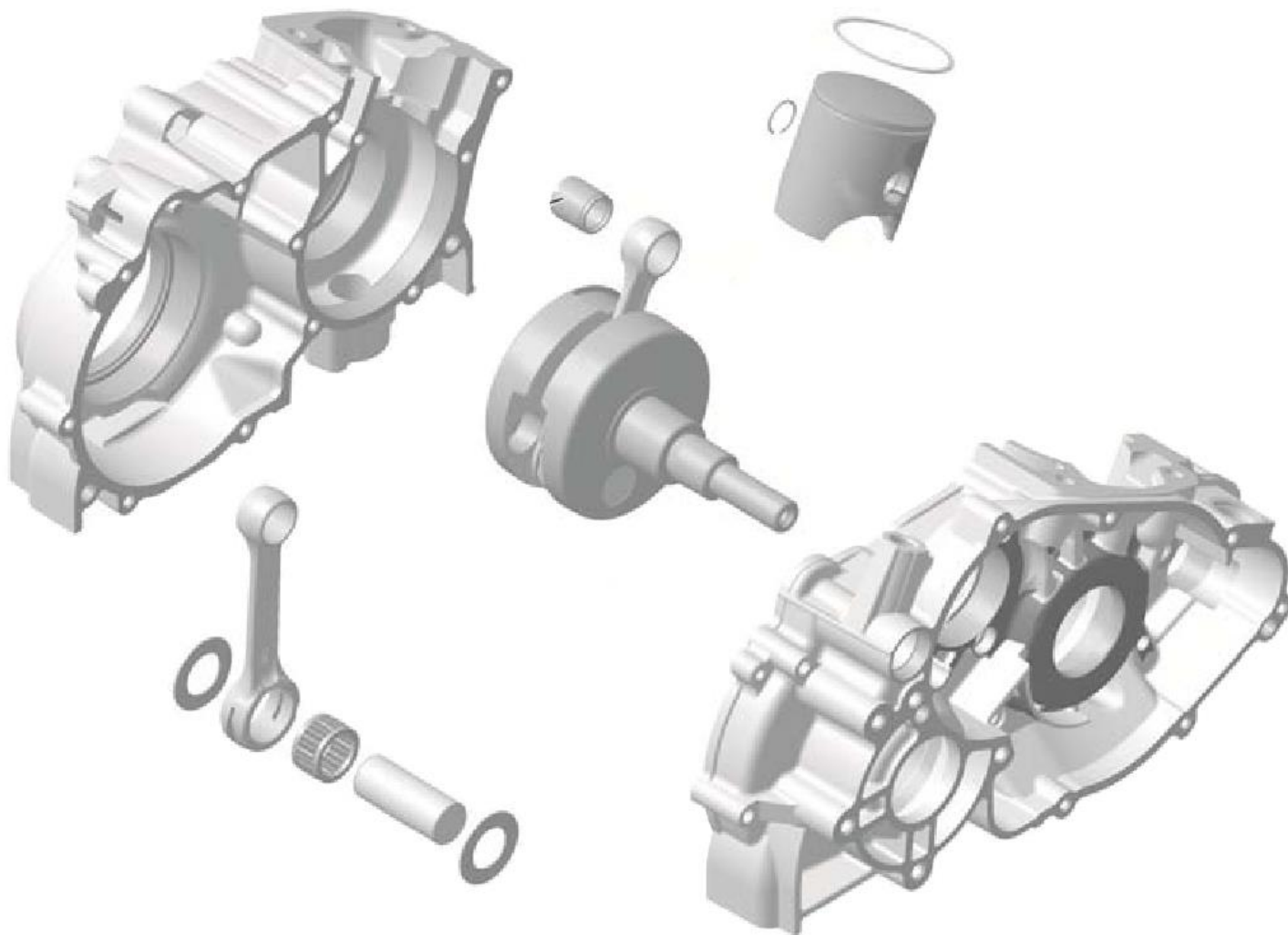

Without screws or gaskets.

The aim of the exploded drawings is to identify the principles, the functioning and the whole mechanical unit

...Section D.2

<i>PHOTO OF THE CRANKSHAFT & CONROD</i>	<i>PHOTO OF THE CONROD</i>
	
<i>DRAWING OF THE PISTON</i>	
	

...Section D.2

PHOTO OF THE INSIDE OF THE RH
CRANKCASE

PHOTO OF THE INSIDE OF THE LH
CRANKCASE

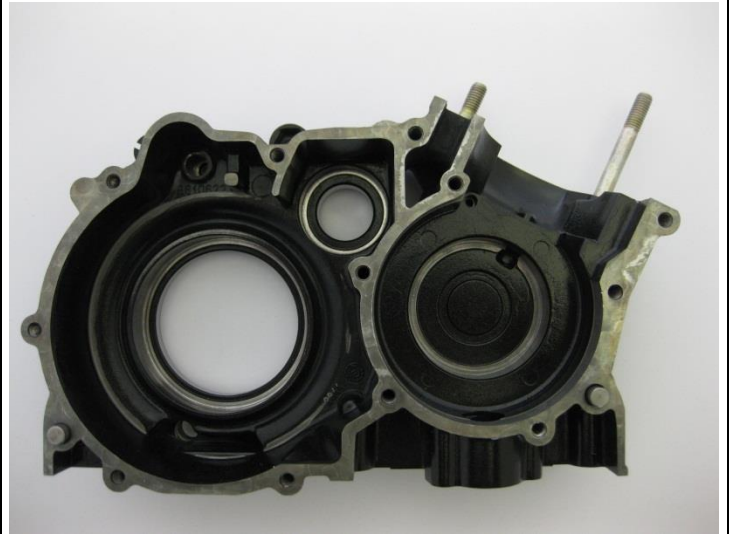
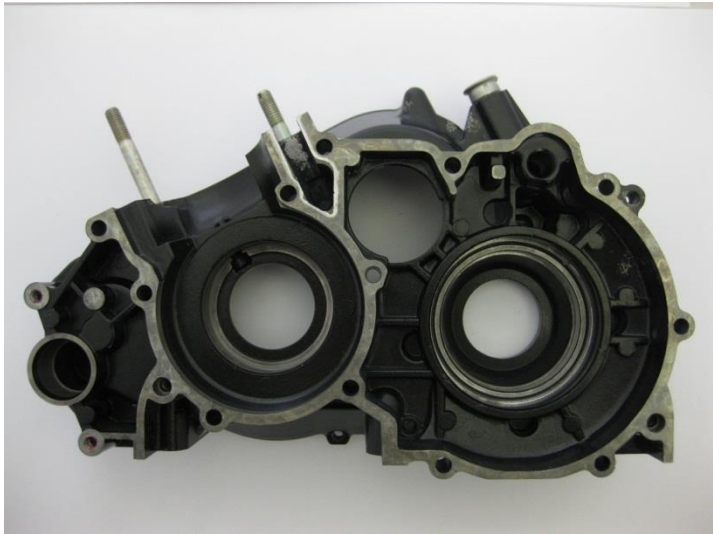

DRAWING OF THE CRANKSHAFT - CON ROD UNIT (DIMENSIONS incl. tolerances, big & small ends thickness, crank mass thickness & diameter)

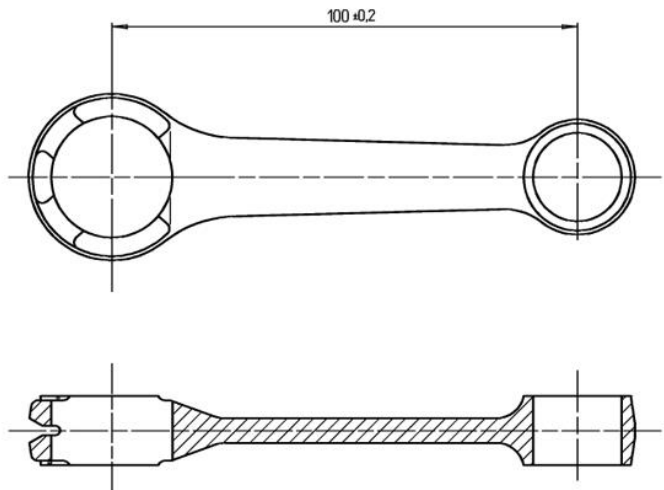
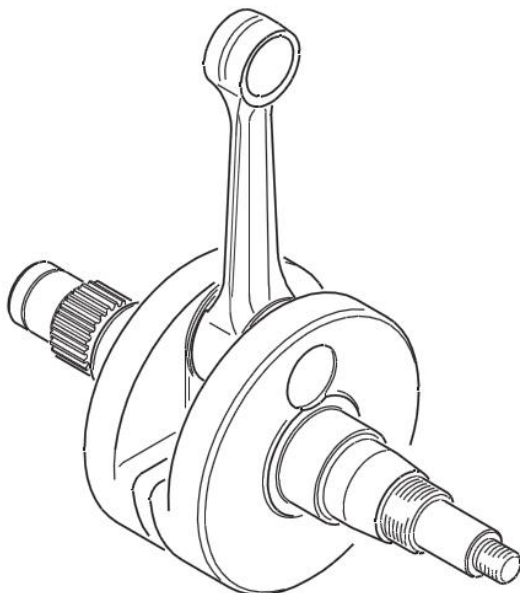

D.3 BALANCE SHAFT & WATER PUMP

EXPLODED DRAWING OF THE BALANCE GEAR, WATER PUMP INCLUDING HOUSING

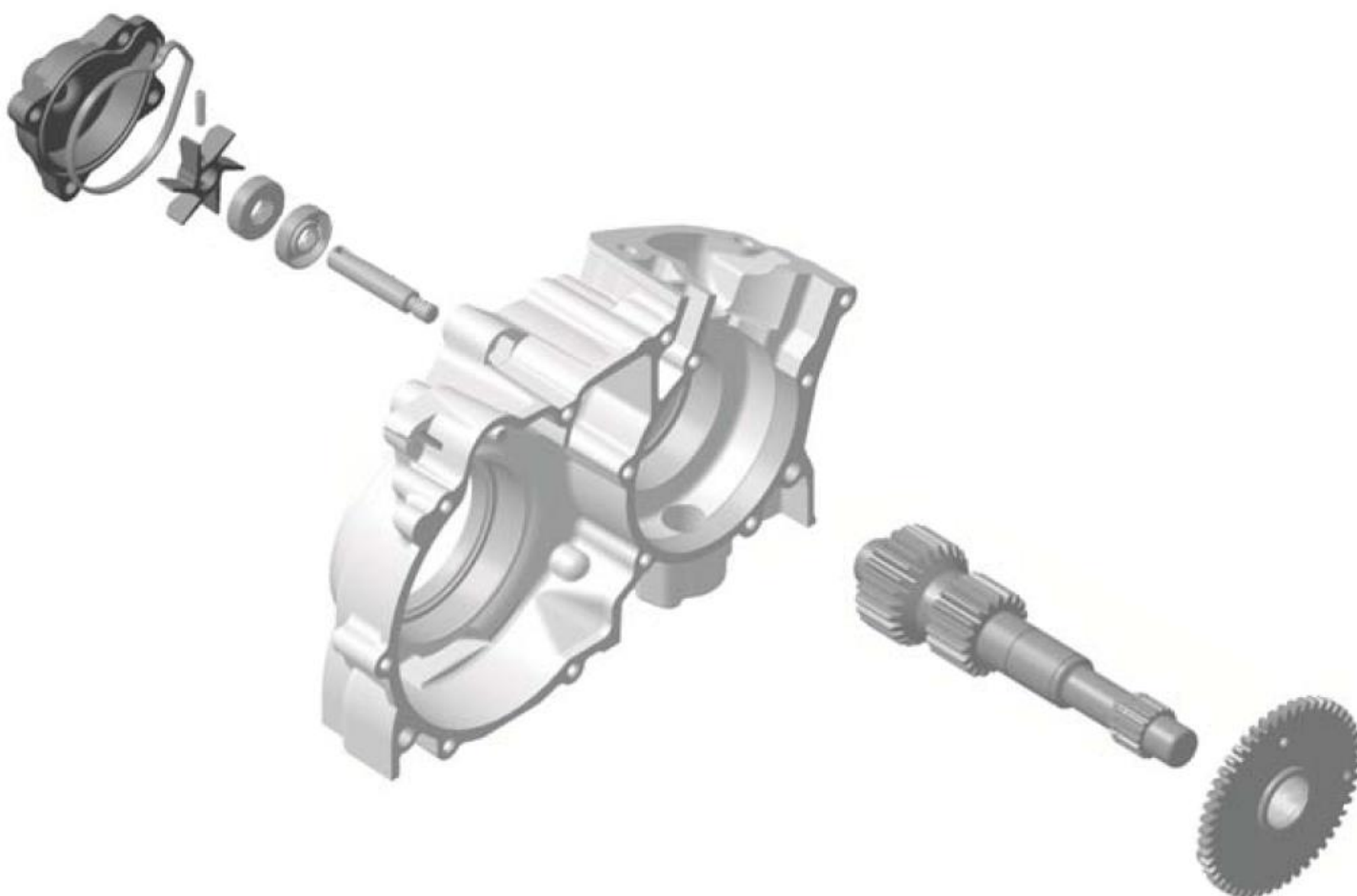

Without screws or gaskets.

The aim of the exploded drawings is to identify the principles, the functioning and the whole mechanical unit

...Section D.3

PHOTO OF THE BALANCE GEAR



PHOTO OF THE WATER PUMP IMPELLER

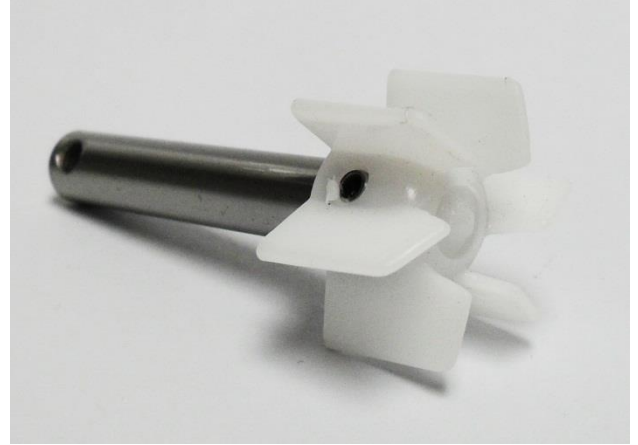

DRAWING OF THE BALANCE GEAR
(DIMENSIONS incl. tolerances)

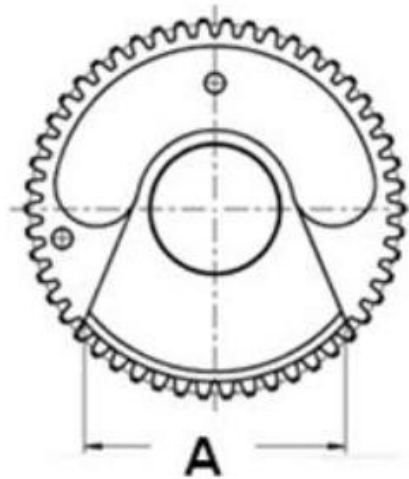

Dimension A (Widest part of balance weight)
53.0mm +/- 0.5 or 57.0mm +/- 0.5
Minimum Dry Weight: 240 grams

D.4 REED VALVE & CLUTCH

TECHNICAL DRAWING (exploded view) OF THE CLUTCH ASSEMBLY

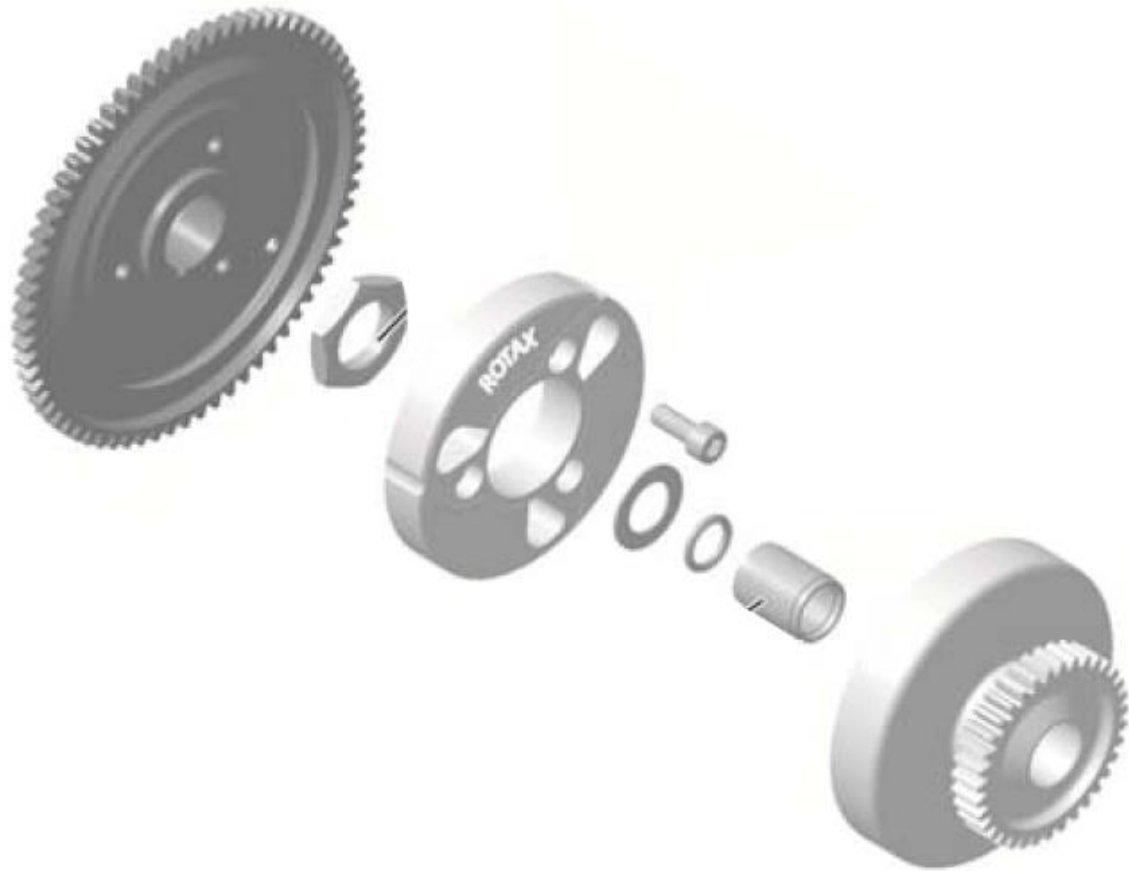

TECHNICAL DRAWING (exploded view) OF THE REED VALVE

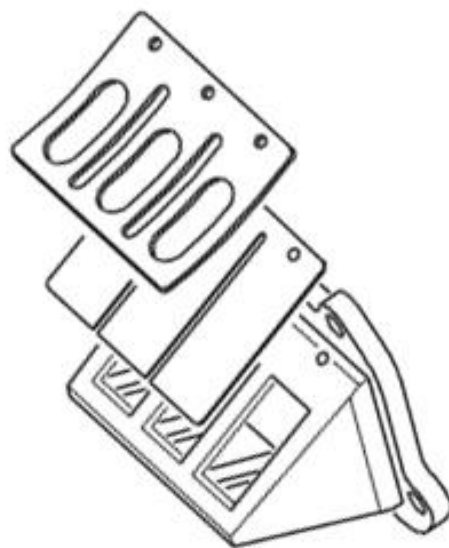

The aim of the exploded drawings is to identify the principles, the functioning and the whole mechanical unit

... Section D.4

*DRAWING OF THE REED VALVE
(DIMENSIONS incl. tolerances)*

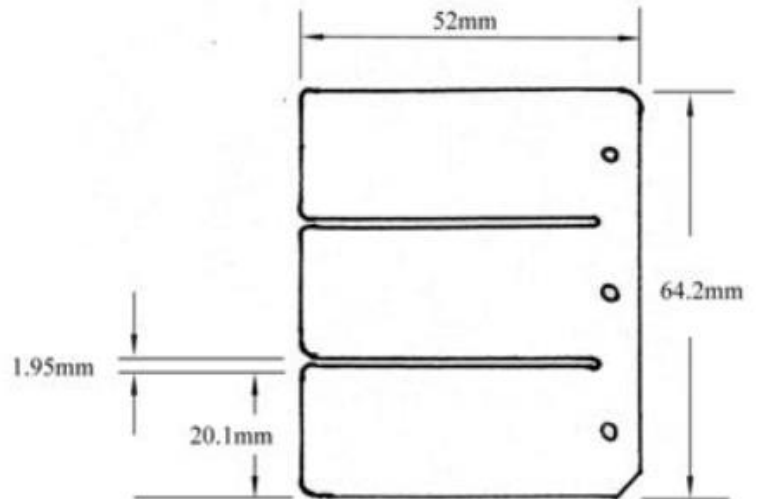

*DRAWING OF THE REED VALVE COVER
(only basic engine)*



D.5 EXHAUST SYSTEM

PHOTO OF THE EXHAUST MANIFOLD



Maximum inner diameter of exhaust socket is:-
- 37.5mm (125 Max DD2 EVO)

PHOTO OF THE EXHAUST



Exhaust for 125 Max DD2 EVO

... Section D.5

*TECHNICAL DESCRIPTIONS
OF THE EXHAUST (Art. 8.9.3 of HR)*

<i>Weight in g</i>	- 125 MAX DD2 EVO: <u>4000G</u>	<i>Minimum</i>

TECHNICAL DRAWING

It must include all the information necessary to build this exhaust.

Tuned pipe with 180° elbow and silencer are two separate pieces. The silencer is fixed with 2 springs to the 180° elbow and two springs to the tuned pipe. The silencer can be turned that the 90° elbow outlet of the silencer shows either downwards towards the asphalt (preferred version for lowest noise emissions) or towards the back. Silencer end cap with 90° elbow is mandatory to be used for version 3.



... Section D.5

EXPLODED DRAWING AND DESIGNATION OF THE POWER VALVE COMPONENTS

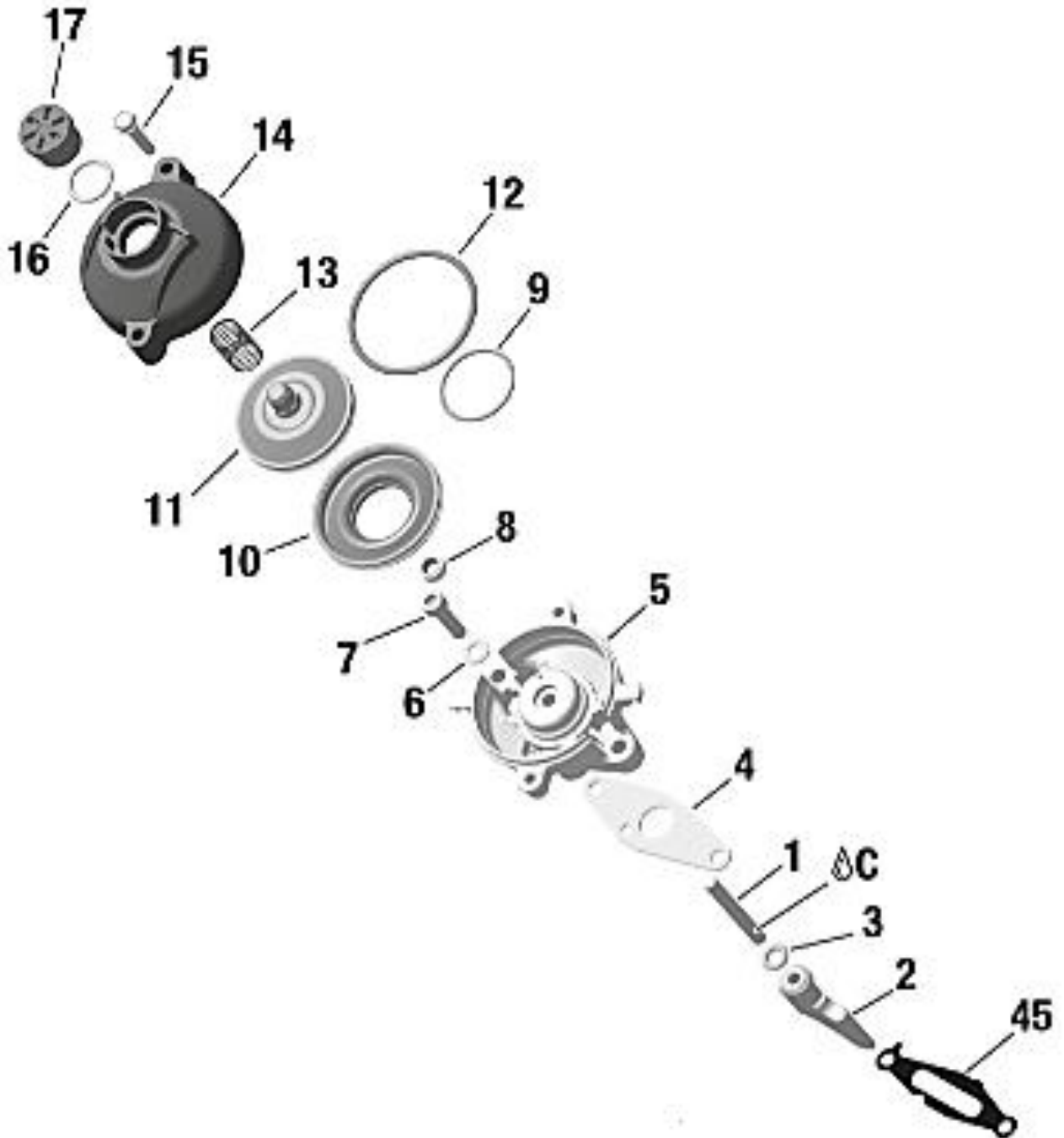

The aim of the exploded drawings is to identify the principles, the functioning and the whole mechanical unit

D.6 STARTER

EXPLODED DRAWING OF THE STARTING UNIT AND OF ITS HOUSING

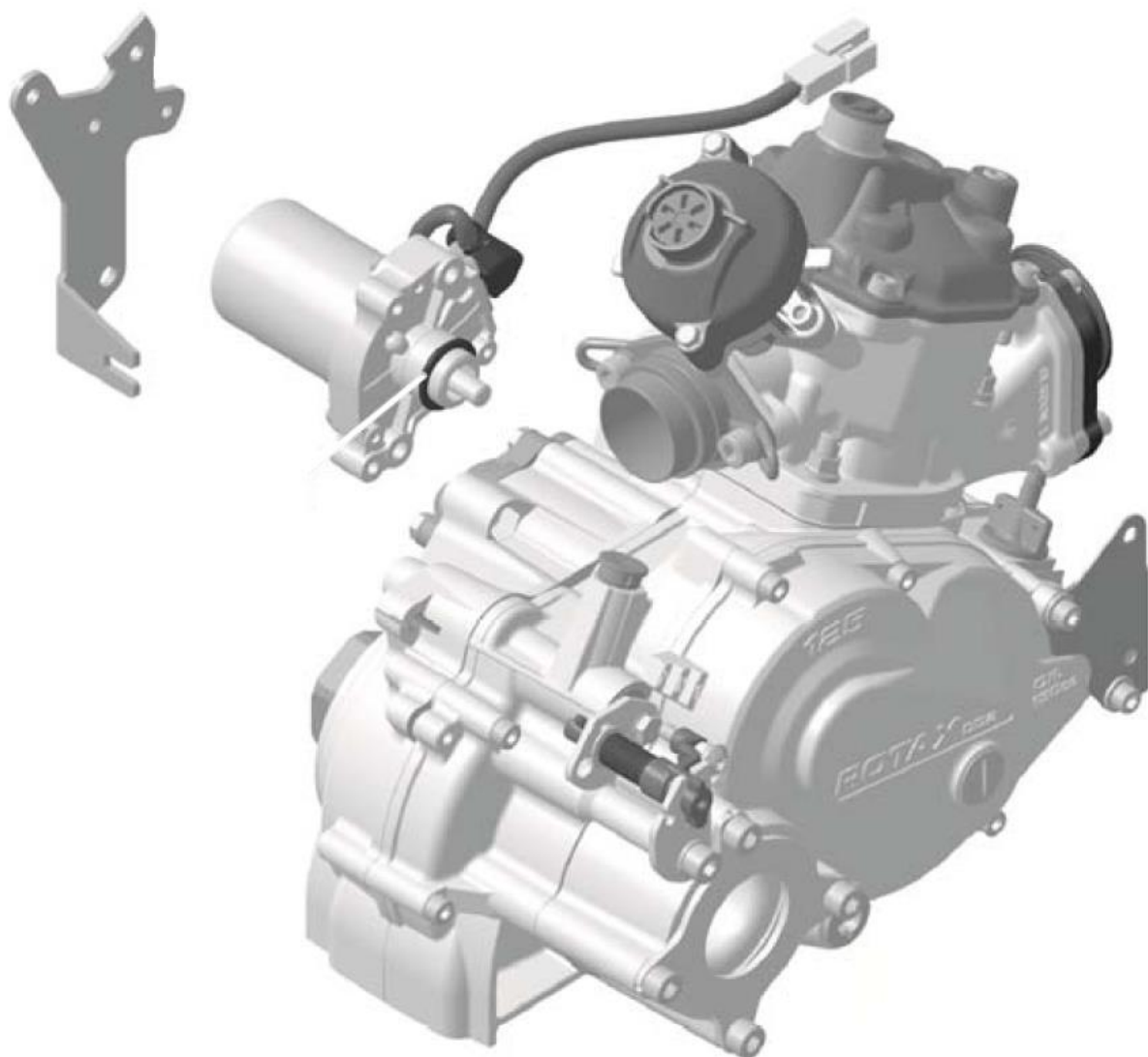

Without screws or gaskets.

The aim of the exploded drawings is to identify the principles, the functioning and the whole mechanical unit

D.8 ELECTRICAL SYSTEM

IGNITION SYSTEM

IGNITION SYSTEM														
<i>Ignition homologation No.</i>					Dellorto Ignition System									
<i>Ignition homologation No.</i>					Ignition Coil is labelled with two stickers " BRP 666820 " & " NIG0105 "									
<i>Ignition homologation No.</i>					Electronic box is labelled with sticker " 666816, 125 MAX DD2 evo "									
<i>Ignition homologation No.</i>														
Code					F125 --/M/18					Color yellow				
Tr/min	1000	2000	3000	4000	5000	6000	7000	8000	9000	10000	11000	12000	13000	14000
° adv														

